

Safety Valves

Type 06205



Safety Valves, brass,
type tested TÜV-SV. 746. D/G, orifice $d_0=7\text{mm}$ TÜV-SV.651. D/G

Standard safety valve
 with FPM valve seal, open bonnet,
 with discharge holes, with lifting device
 Inlet: male thread type G (BSPP) acc. to ISO 228/1

Part No. 06205.X.0000

Available options - on request only:

- stainless steel spring - material DIN EN 1.4571
- external parts nickel plated

Applications:

Provided as safety device for protection against excessive pressure in stationary and moveable pressure vessels. Approved for air and similar gases.

Working temperature:

TÜV-SV.651. D/G: $-10^\circ\text{C} / 14^\circ\text{F}$ (263K) up to $+160^\circ\text{C} / +320^\circ\text{F}$ (433K)

TÜV-SV.746. D/G: $-10^\circ\text{C} / 14^\circ\text{F}$ (263K) up to $+160^\circ\text{C} / +248^\circ\text{F}$ (433K)



Materials	DIN EN	ASTM
1 Body	CW612N	B 283 UNS C37700
2 Valve seal	FPM (Viton)	
3 Disc	CW612N	B 283 UNS C37700
4 Stem	CW612N	B 283 UNS C37700
5 Bonnet	CW612N	B 283 UNS C37700
6 Spring	1.1200	A 576 Grade 1045
7 Stem guide	PTFE	
8 Lifting device	CW612N	B 283 UNS C37700
9 Closing cap	CW507L	B 30 UNS C26800

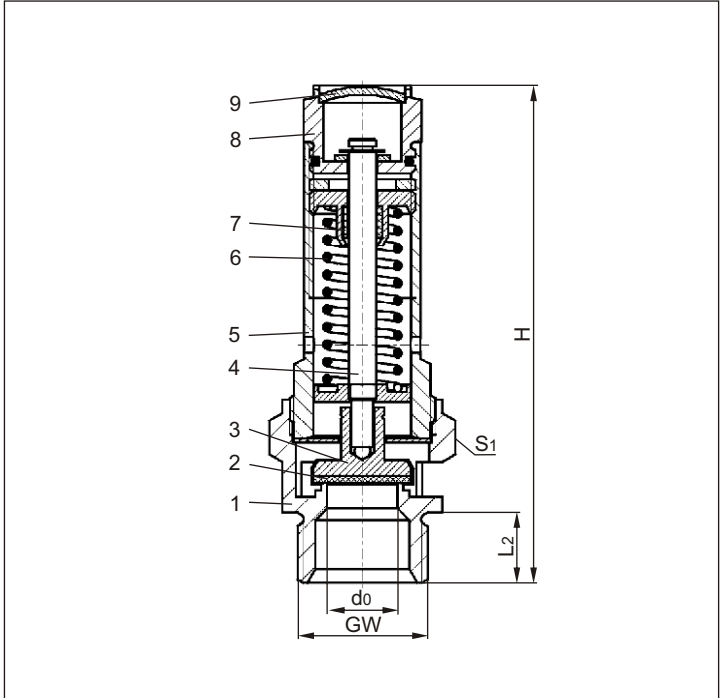

Essential: Valves are delivered at a set pressure, therefore when ordering please confirm set pressure, medium and temperature.

Standard marking acc. to Pressure Equipment Directive 97/23/EC (PED).



Type 06205	Technical data								
	Nominal size	GW	1/4	3/8	1/2	1/2	3/4	1	1-1/4
Orifice	d_0	7	7	7	12	15	18	20	
Dimension code	.X.	0200	0300	0704	0400	0600	1000	1200	
Set pressure range	bar	0.4-30	0.4-30	0.4-30	0.2-22	0.2-16	0.2-18	0.2-16	
Height	H	60	60	67	78	92	110	125	
Length	L_2	10	10	12	12	15	18	20	
Wrench size across flats	S_1	21	21	24	27	32	41	48	
Weight	ca. kg	0.07	0.07	0.17	0.17	0.27	0.48	0.75	
Coeff. of discharge from 3.0 bar	α_w	0.60	0.60	0.60	0.47	0.63	0.63	0.63	

Dimensions in mm.

Safety Valves

Type 06205

HEROSE



Discharge capacities

Calculation of mass flow acc. to AD2000-Merkblatt A2

Medium:

Air in m³/h at 0°C and 1013.25 mbar

The capacity indicated below is for a fully opened valve.

d₀ - orifice

A₀ - flow area

Set pressure in bar (ü)	G	1/4	3/8	1/2	1/2	3/4	1	1-1/4
	d ₀ (mm)	7.0	7.0	7.0	12.0	15.0	18.0	20.0
	A ₀ (mm ²)	38.48	38.48	38.48	113.1	176.7	254.5	314.2
Medium	Air							
0.2	-	-	-	30	60	86	106	
0.4	20	20	20	44	89	128	158	
0.6	23	23	23	52	105	151	186	
0.8	27	27	27	61	123	177	219	
1.0	30	30	30	70	142	205	253	
2.0	50	50	50	114	240	345	426	
3.0	68	68	68	156	327	471	581	
4.0	85	85	85	196	410	591	730	
5.0	102	102	102	236	494	711	878	
6.0	120	120	120	276	577	831	1026	
7.0	137	137	137	315	661	951	1175	
8.0	154	154	154	355	744	1071	1323	
9.0	172	172	172	395	827	1192	1471	
10.0	189	189	189	435	911	1312	1619	
12.0	223	223	223	515	1077	1552	1916	
14.0	258	258	258	594	1244	1792	2212	
16.0	293	293	293	674	1411	2032	2509	
18.0	327	327	327	753	-	2273	-	
20.0	362	362	362	833	-	-	-	
22.0	396	396	396	913	-	-	-	
25.0	448	448	448	-	-	-	-	
27.0	483	483	483	-	-	-	-	
30.0	535	535	535	-	-	-	-	