

Features

- ☆ Use with practically zero leakage present and non-porous applications
- ☆ Available with connection plate in aluminium (AD) and composite PPS(D)
- ☆ Supplies with a push-in connector for compressed air, through-flow silencer and mounting brackets



Specifications

Air supply pressure max	bar	7
Noise level	dBA	60–65
Temperature range	°C	–20–80
Weight	g	530–620,690–780
Material		AL,PPS,NBR,SS

Technical Parameters

Model	Air supply pressure bar	Max.vacuum level (-kPa)	Max.vacuum flow (l/min)	Air consumption (l/min)	Weight(PPS materials) g	Min tube inner Φ (within 2m)		
						Air supply	Vacuum	EXhaust
AH40	6	99.8	150	155	675	>6	>8	>10
AH120		100.8	530	440	837	>9	>15	>19

How to Order

AH40 – D – N – A

① ② ③ ④

① Model

AH40
AH120

② Connection Plate

	Air Supply	Vacuum	Exhaust	Material
D	NPSF1/8"	G3/4"	G3/4"	PPS
B	NPSF1/8"	NPT3/4"	NPT3/4"	PPS
AD	G1/4"	G3/4"	G3/4"	AL
E	NPT1/4"	NPT3/4"	NPT3/4"	AL

③ Sealing

N	NBR
E	EPDM
V	VITON

④ Non-Return Valve

A	Yes
-	No

Vacuum flow(l/min)at different vacuum levels(-kPa)

Model	-kPa	Air supply pressure	Air consumption	0	10	20	30	40	50	60	70	80	90	99	Max.vacuum level
AH40	6 bar	155 l/min	150	145	105	52.5	27.5	20.5	15	8.5	5.5	3	0.2	-99.8kPa	
AH120			440 l/min	530	420	265	141	85	65	45	33	21.5	6	0.5	-100.8kPa

Evacuation time(s/l)to reach different vacuum levels(-kPa)

Model	-kPa	Air supply pressure	Air consumption	10	20	30	40	50	60	70	80	90	99	Max.vacuum level
AH40	6 bar	155 l/min	0.035	0.078	0.18	0.32	0.64	1.3	1.8	2.6	3.9	9.8	-99.8kPa	
AH120			440 l/min	0.02	0.036	0.08	0.14	0.25	0.38	0.66	1.08	3.6	8.5	-100.8kPa

• AH40

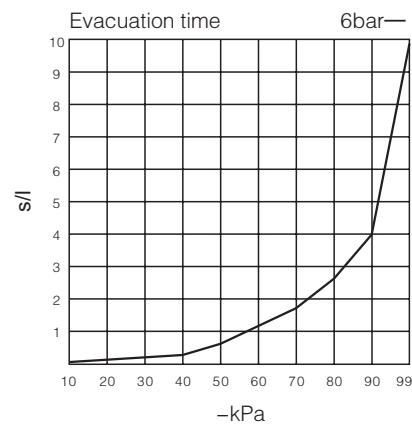
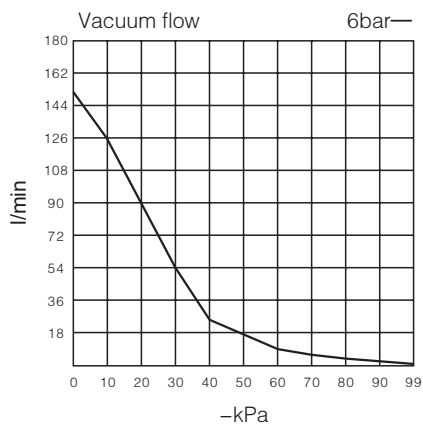

• AH120

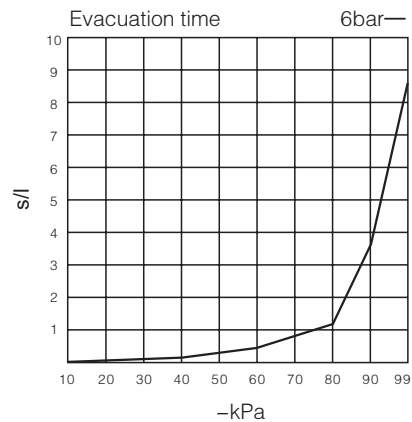
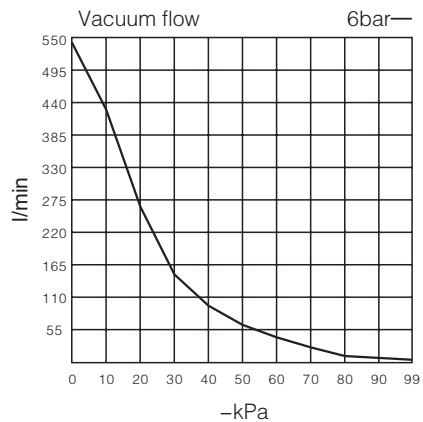

Dimensions (mm)

• AH40

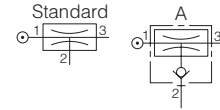
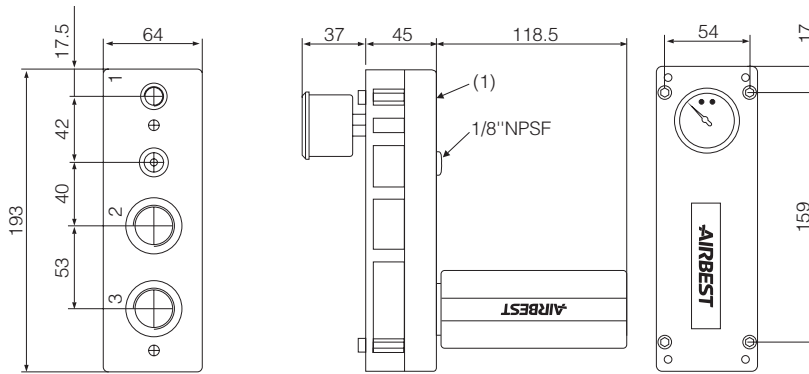

	1	2	3
D	NPSF1/8"	G3/4"	G3/4"
B	NPSF1/8"	NPT3/4"	NPT3/4"
AD	G1/4"	G3/4"	G3/4"
E	NPT1/4"	NPT3/4"	NPT3/4"

• AH120

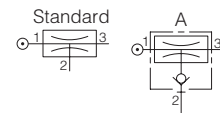
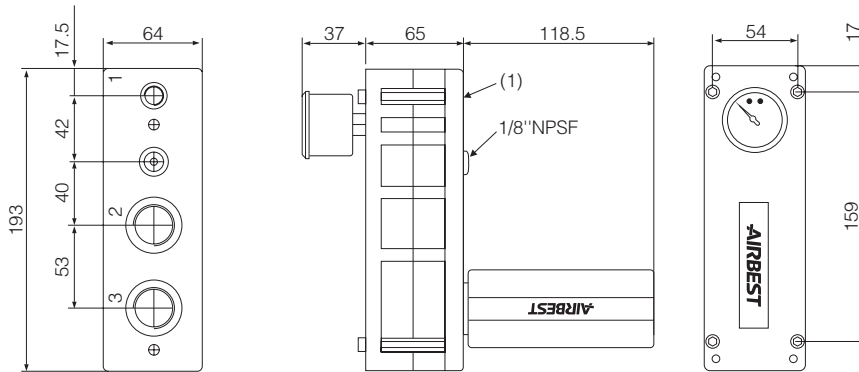

	1	2	3
D	NPSF1/8"	G3/4"	G3/4"
B	NPSF1/8"	NPT3/4"	NPT3/4"
AD	G1/4"	G3/4"	G3/4"
E	NPT1/4"	NPT3/4"	NPT3/4"

Repair kits

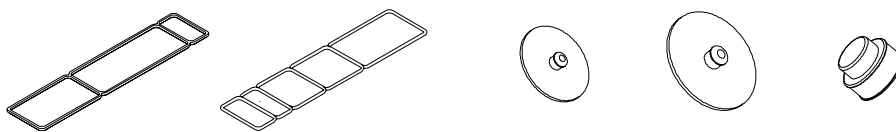

Model	Ordering Code		
	NBR	VITON	EPDM
AH40	01.0025.402	01.0025.602	01.0025.802
AH120	01.0075.404	01.0075.604	01.0075.804