



Features

- ☆ Medium vacuum levels to -90 kPa
- ☆ Operates at 3.4bar
- ☆ Good for handling porous materials or if leakage is present
- ☆ Energy-Saving(ES)available
- ☆ Available with connection plate in aluminium(AD)and composite PPS(D)
- ☆ Supplies with a push-in connector for compressed air,through-flow silencer and mounting brackets

Specifications

Air supply pressure max	bar	7
Air supply pressure(opt)	bar	3.4
Noise level	dBA	60~65
Temperature range	°C	~20-80
Weight	g	750-120
Material		AL, PPS, SS, PA, NBR

Technical Parameters

Model	Max.vacuum level (-kPa)	Max.vacuum flow (l/min)	Air consumption (l/min)	Weight(PPS materials) g	Min tube inner Φ (within 2m)		
					Air supply	Vacuum	EXhaust
AM25L	92	420	116-185	675	>4	>12	>12
AM50L		700	230-370	675	>6	>15	>15
AM75L		950	365-610	837	>8	>19	>22
AM100L		1010	445-720	837	>8	>19	>22
AM125L		1400	545-780	1075	>10	>25	>32
AM150L		1500	655-810	1075	>10	>25	>32

How to Order

AM25L - D - N - A - ES

① ② ③ ④ ⑤

① Model

AM25L AM100L
AM50L AM125L
AM75L AM150L

③ Sealing

N	NBR
E	EPDM
V	VITON

④ Non-Return Valve

A	Yes
-	No

② Connection Plate

AM25L-AM100L

	Air Supply	Vacuum	Exhaust	Material
D	NPSF1/8"	G3/4"	G3/4"	PPS
B	NPSF1/8"	NPT3/4"	NPT3/4"	PPS
AD	G1/4"	G3/4"	G3/4"	Aluminum
E	NPT1/4"	NPT3/4"	NPT3/4"	Aluminum

AM125L-AM150L

	Air Supply	Vacuum	Exhaust	Material
D	G1/4"	G1*	G1*	PPS
B	NPT1/4"	NPT1*	NPT1*	PPS
AD	G1/4"	G1*	G1*	Aluminum
E	NPT1/4"	NPT1*	NPT1*	Aluminum

⑤ Control device

	Control device	Control device
PD	Electric air supply	PVD Electric control(air supply+vacuum breaking)Combination
PQ	Pneumatic air supply	PVQ Pneumatic control(air supply+vacuum breaking)Combination
VD	Electric control vacuum breaking	ES Energy-saving
VQ	Pneumatic control vacuum breaking	- NO

• AM25L

Vacuum flow(l/min)at different vacuum levels(-kPa)

Air supply pressure bar	Air consumption l/min	Vacuum flow (l/min) at different vacuum levels(-kPa)										Max vacuum level -kPa
		0	10	20	30	40	50	60	70	80	90	
3.4	116	360	180	115	80	43	30	22.5	15.5	7.5	1.2	92
6	185	420	240	125	100	82	65	38	12.5	3.5	-	89

Evacuation time(s/l)to reach different vacuum levels(-kPa)

Air supply pressure bar	Air consumption l/min	Evacuation time (s/l) to reach different vacuum levels(-kPa)									Max vacuum level -kPa
		10	20	30	40	50	60	70	80	90	
3.4	116	0.022	0.06	0.11	0.21	0.4	0.65	0.95	1.60	4	92
6	185	0.018	0.05	0.08	0.18	0.25	0.40	0.62	1.55	-	89

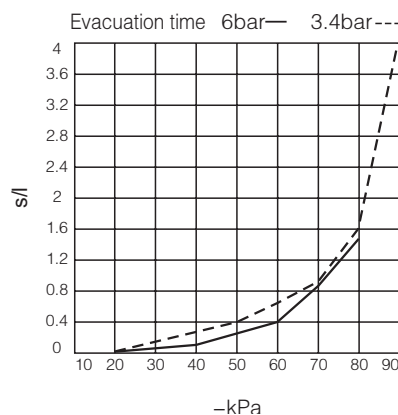
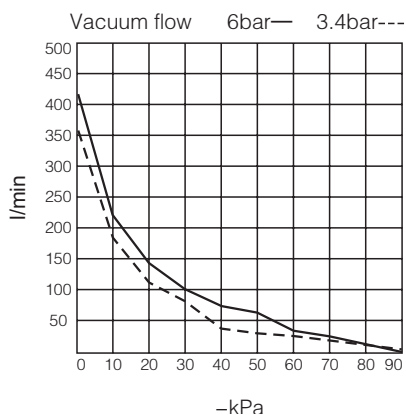

• AM50L

Vacuum flow(l/min)at different vacuum levels(-kPa)

Air supply pressure bar	Air consumption l/min	Vacuum flow (l/min) at different vacuum levels(-kPa)										Max vacuum level -kPa
		0	10	20	30	40	50	60	70	80	90	
3.4	230	600	320	250	135	75	60	46	30	13	1.5	92
6	370	700	510	290	195	160	115	70	22	8	-	89

Evacuation time(s/l)to reach different vacuum levels(-kPa)

Air supply pressure bar	Air consumption l/min	Evacuation time (s/l) to reach different vacuum levels(-kPa)									Max vacuum level -kPa
		10	20	30	40	50	60	70	80	90	
3.4	230	0.014	0.031	0.06	0.10	0.20	0.34	0.50	0.80	2.5	92
6	370	0.01	0.022	0.048	0.08	0.11	0.20	0.35	0.78	-	89

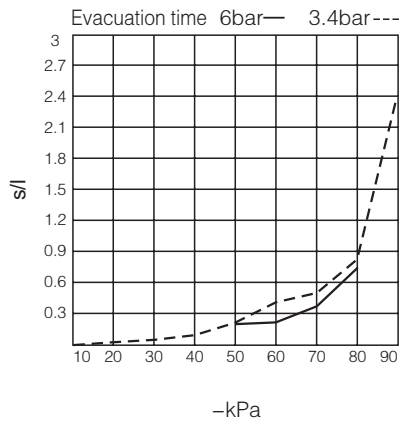
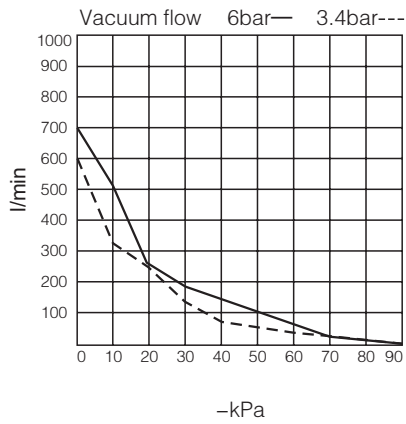

• AM75L

Vacuum flow(l/min)at different vacuum levels(-kPa)

Air supply pressure bar	Air consumption l/min	Vacuum flow (l/min) at different vacuum levels(-kPa)										Max vacuum level -kPa
		0	10	20	30	40	50	60	70	80	90	
3.4	365	760	445	340	175	110	85	70	43	20	1.8	92
6	610	950	710	380	285	230	170	100	32	11	-	89

Evacuation time(s/l)to reach different vacuum levels(-kPa)

Air supply pressure bar	Air consumption l/min	Evacuation time (s/l) to reach different vacuum levels(-kPa)									Max vacuum level -kPa
		10	20	30	40	50	60	70	80	90	
3.4	365	0.012	0.029	0.058	0.095	0.18	0.31	0.46	0.89	1.5	92
6	610	0.009	0.019	0.045	0.075	0.13	0.18	0.31	0.70	-	89

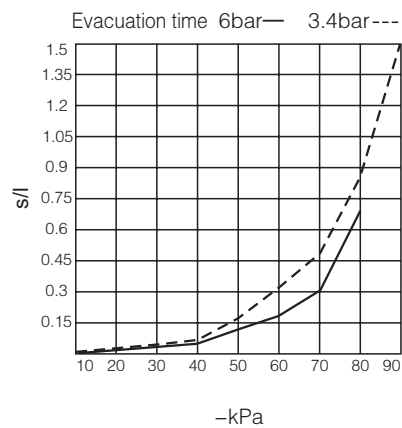
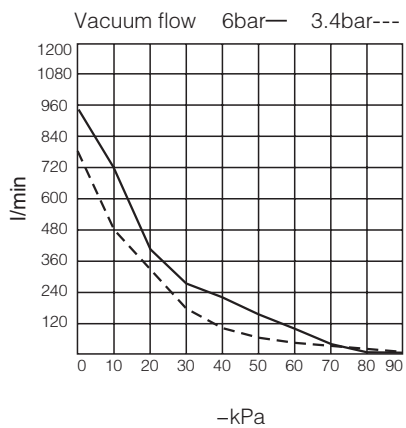

• AM100L

Vacuum flow(l/min)at different vacuum levels(-kPa)

Air supply pressure bar	Air consumption l/min	Vacuum flow (l/min) at different vacuum levels(-kPa)										Max vacuum level -kPa
		0	10	20	30	40	50	60	70	80	90	
3.4	445	850	550	430	280	145	115	85	60	28	2.2	92
6	720	1010	800	460	385	310	215	125	42	15.5	-	89

Evacuation time(s/l)to reach different vacuum levels(-kPa)

Air supply pressure bar	Air consumption l/min	Evacuation time (s/l) to reach different vacuum levels(-kPa)									Max vacuum level -kPa
		10	20	30	40	50	60	70	80	90	
3.4	455	0.010	0.025	0.043	0.075	0.11	0.19	0.27	0.45	1.2	92
6	720	0.007	0.018	0.038	0.055	0.08	0.12	0.19	0.47	-	89

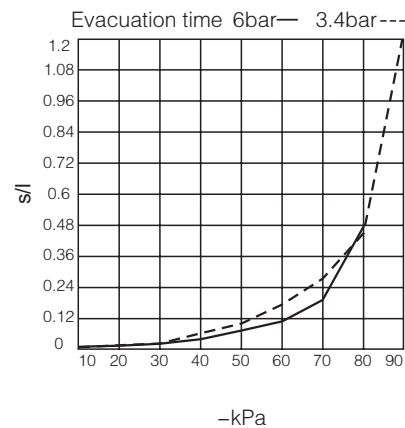
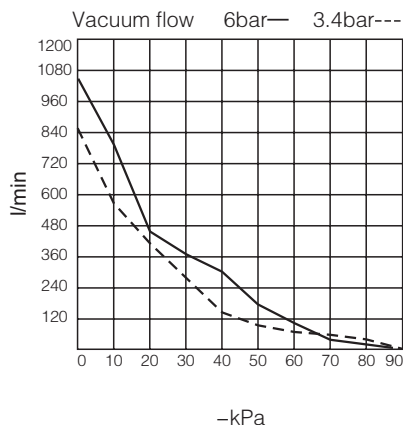

• AM125L

Vacuum flow(l/min)at different vacuum levels(-kPa)

Air supply pressure bar	Air consumption l/min	Vacuum flow (l/min) at different vacuum levels(-kPa)										Max vacuum level -kPa
		0	10	20	30	40	50	60	70	80	90	
3.4	545	1150	760	530	350	180	148	115	78	34.5	3.5	92
6	780	1400	1120	560	490	355	260	150	50	25	-	89

Evacuation time(s/l)to reach different vacuum levels(-kPa)

Air supply pressure bar	Air consumption l/min	Evacuation time (s/l) to reach different vacuum levels(-kPa)									Max vacuum level -kPa
		10	20	30	40	50	60	70	80	90	
3.4	545	0.006	0.015	0.029	0.052	0.085	0.145	0.202	0.330	1	92
6	780	0.005	0.013	0.026	0.045	0.062	0.115	0.194	0.56	-	89

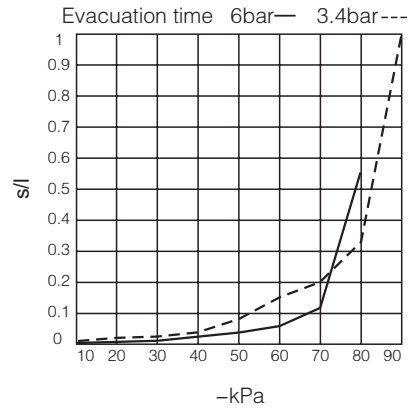
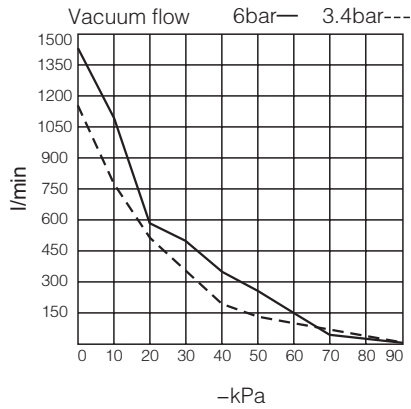

• AM150L

Vacuum flow(l/min)at different vacuum levels(-kPa)

Air supply pressure bar	Air consumption l/min	Vacuum flow (l/min) at different vacuum levels(-kPa)											Max vacuum level -kPa
		0	10	20	30	40	50	60	70	80	90		
3.4	655	1200	830	550	360	215	170	130	90	36	5	92	
6	810	1500	1110	630	560	385	315	210	65	26	-	89	

Evacuation time(s/l)to reach different vacuum levels(-kPa)

Air supply pressure bar	Air consumption l/min	Evacuation time (s/l) to reach different vacuum levels(-kPa)										Max vacuum level -kPa
		10	20	30	40	50	60	70	80	90		
3.4	655	0.005	0.013	0.027	0.045	0.070	0.105	0.23	0.46	0.9	92	
6	810	0.003	0.009	0.014	0.030	0.060	0.095	0.20	0.8	-	89	

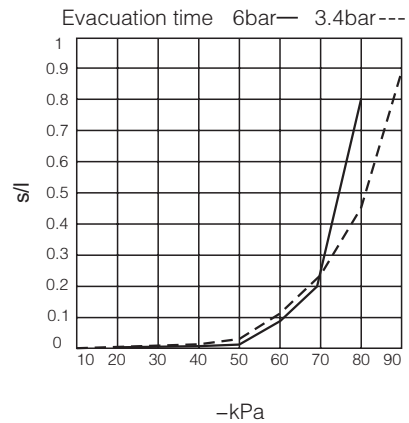
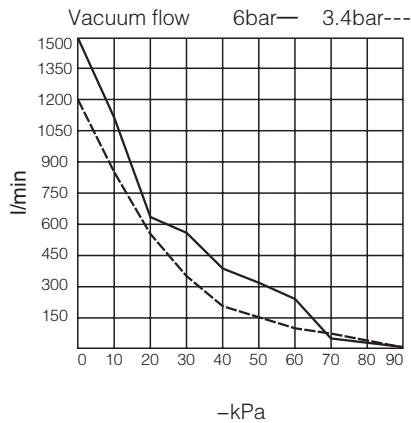

Dimensions (mm)

• AM25L

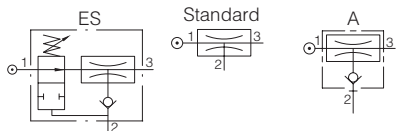

	1	2	3
D	NPSF1/8"	G3/4"	G3/4"
B	NPSF1/8"	NPT3/4"	NPT3/4"
AD	G1/4"	G3/4"	G3/4"
E	NPT1/4"	NPT3/4"	NPT3/4"

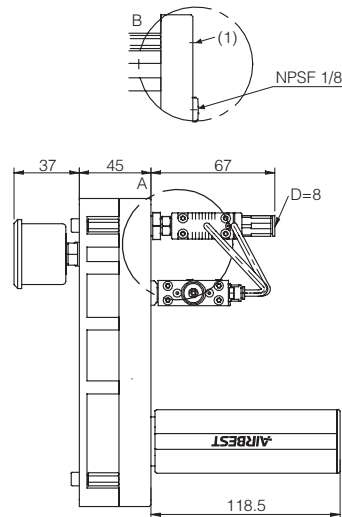
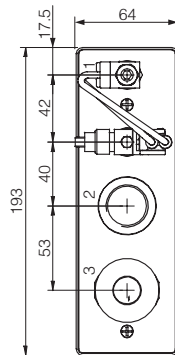

• AM50L

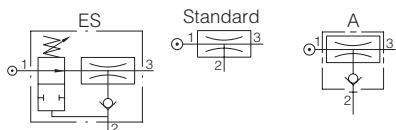

	1	2	3
D	NPSF1/8"	G3/4"	G3/4"
B	NPSF1/8"	NPT3/4"	NPT3/4"
AD	G1/4"	G3/4"	G3/4"
E	NPT1/4"	NPT3/4"	NPT3/4"

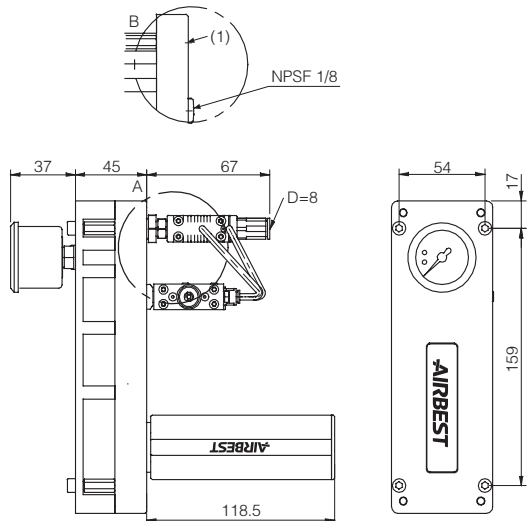
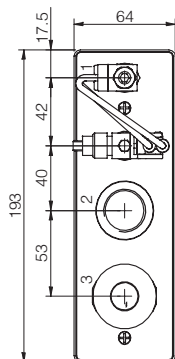

• AM75L

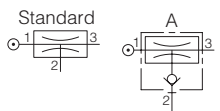

	1	2	3
D	NPSF1/8"	G3/4"	G3/4"
B	NPSF1/8"	NPT3/4"	NPT3/4"
AD	G1/4"	G3/4"	G3/4"
E	NPT1/4"	NPT3/4"	NPT3/4"

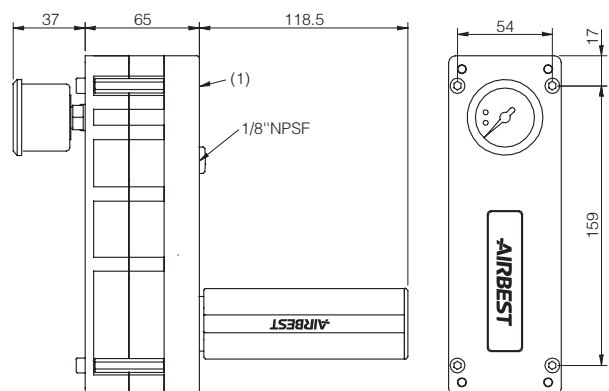
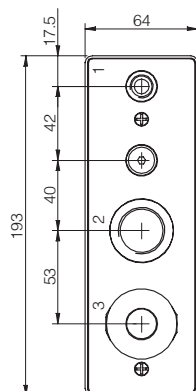

Dimensions (mm)

• AM100L

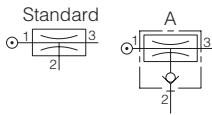

	1	2	3
D	NPSF1/8"	G3/4"	G3/4"
B	NPSF1/8"	NPT3/4"	NPT3/4"
AD	G1/4"	G3/4"	G3/4"
E	NPT1/4"	NPT3/4"	NPT3/4"

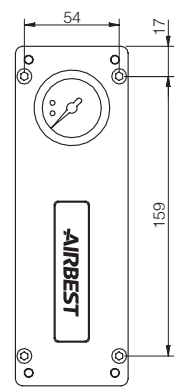
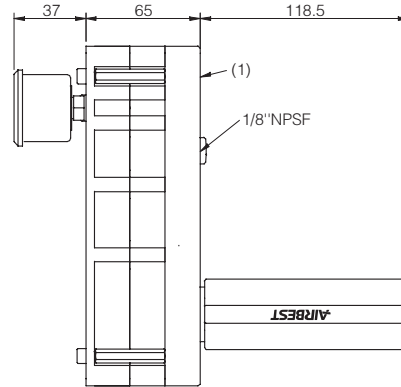
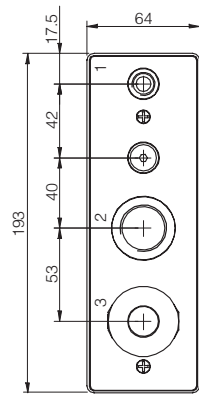

• AM125L

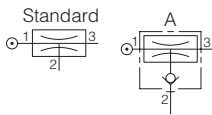

	1	2	3
D	G1/4"	G1*	G1*
B	NPT1/4"	NPT1*	NPT1*
AD	G1/4"	G1*	G1*
E	NPT1/4"	NPT1*	NPT1*

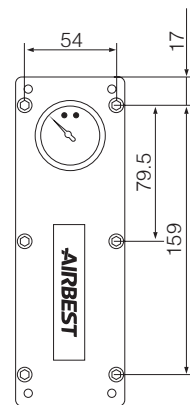
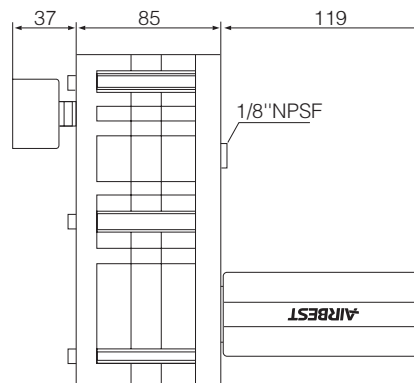
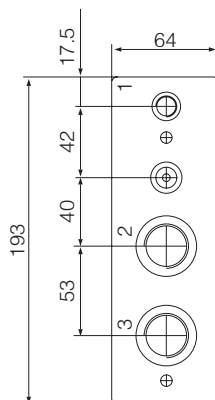

• AM150L

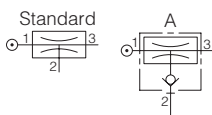

	1	2	3
D	G1/4"	G1*	G1*
B	NPT1/4"	NPT1*	NPT1*
AD	G1/4"	G1*	G1*
E	NPT1/4"	NPT1*	NPT1*

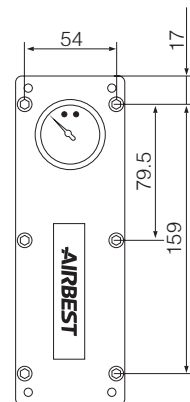
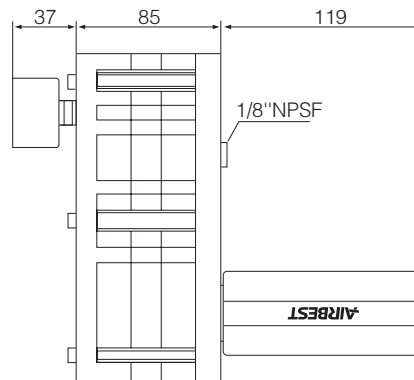
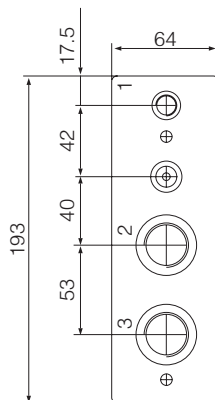

Repair kits

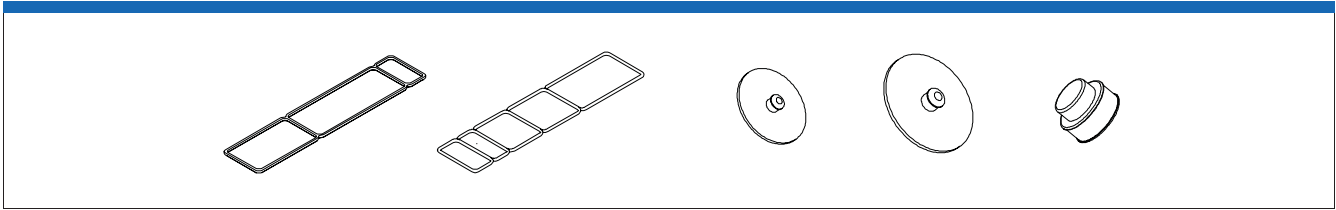

Model	Ordering Code		
	NBR	VITON	EPDM
AM25L	01.0025.402	01.0025.602	01.0025.802
AM50L	01.0025.402	01.0025.602	01.0025.802
AM75L	01.0075.404	01.0075.604	01.0075.804
AM100L	01.0075.404	01.0075.604	01.0075.804
AM125L	01.0125.404	01.0125.604	01.0125.804
AM150L	01.0150.404	01.0150.604	01.0150.804

Vacuum Pumps

ABM

ABX

ABM/ABX
Combined type

AM

AL

AH

AM
Combined type

AL
Combined type

AH
Combined type

AZL 112

AZL212

ACP

ACPF

ACV

AZH

AZU

ASBP