

Mounting Accessories for Cylinders

Mountings for compact UNITOP in aluminium

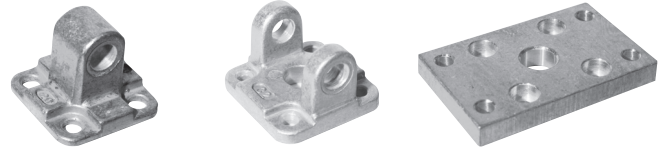

Standard executions		
Version	Symbol	Type
Rear eye		CM..ALUN
Rear clevis		CF..ALUN
Flange		FL..ALUN



Technical data	
Material	Die-cast aluminium
Treatment	Sifting

Note: The mounting screws are to be ordered separately.
For screws see page 1.101.1 (VBU)

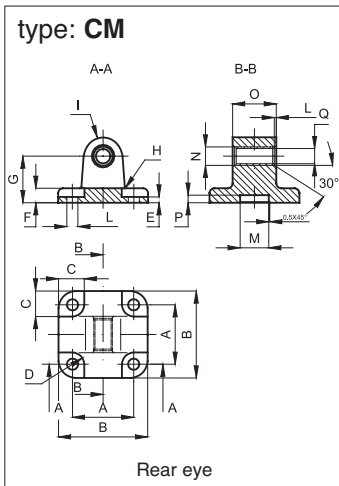

Code	Item	For cyl. ø mm	A	B	C	D	E	F	G	H	I	L	M	N	O	P	Q	Weight (g)
040701	CM12-16ALUN	12-16	18	27	10	4,5	2,6	6	16	2	6	4,5	10	8	12	3	6	17
040702	CM20ALUN	20	22	34	11	5	2,6	6	20	2	8	5,5	12	10	16	3	8	21
040703	CM25ALUN	25	26	38	11	5	2,6	6	20	2	8	5,5	12	10	16	3	8	27

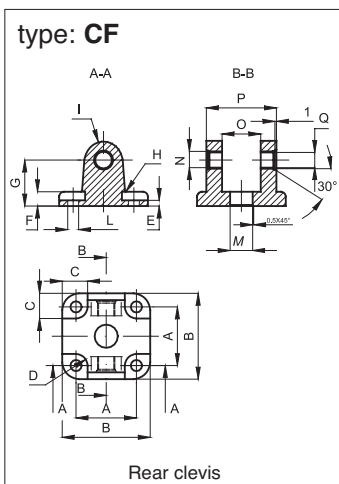

Code	Item	For cyl. ø mm	A	B	C	D	E	F	G	H	I	L	M	N	O	P	Q	Weight (g)
040711	CF32ALUN	32	32	48	13,5	5,5	5,5	9	22	2,5	10	6,6	14	12	26	45	10	60
040712	CF40ALUN	40	42	58	13,5	5,5	5,5	9	25	2,5	12,5	6,6	14	14	28	52	12	104
040713	CF50ALUN	50	50	66	15,5	7,5	6,5	11	27	2,5	12,5	9	18	14	32	60	12	142
040714	CF63ALUN	63	62	83	18	7,5	6,5	11	32	4	15	9	18	18	40	70	16	240
040715	CF80ALUN	80	82	102	19	9	10	13	36	4	15	11	23	18	50	90	16	420
040716	CF100ALUN	100	103	123	19	9	10	15	41	4	20	11	28	23	60	110	20	721

The pin is to be ordered separately: for the pin see page 1.98.2 (SEC..AQIS).

Mounting Accessories for Cylinders

Mountings for compact UNITOP in aluminium



type: **FL**

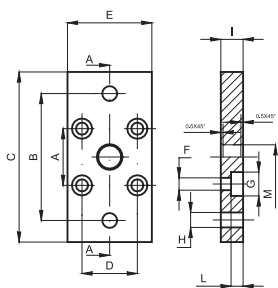

Flange $\varnothing 12 \div 25$ mm.

Code	Item	For cyl. \varnothing mm	A	B	C	D	E	F	G	H	I	L	M	Weight (g)
040721	FL12-16ALUN	12-16	18	43	55	18	29	4,5	9	5,5	10	5,4	10	34
040722	FL20ALUN	20	22	55	70	22	36	5,5	10	6,6	10	5,4	12	55
040723	FL25ALUN	25	26	60	76	26	40	5,5	10	6,6	10	5,4	12	68

type: **FL**

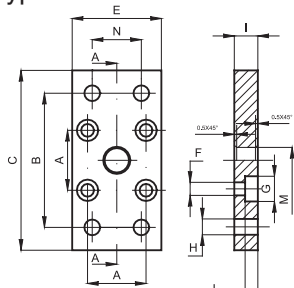

Flange $\varnothing 32 \div 100$ mm.

Code	Item	For cyl. \varnothing mm	A	B	C	D	E	F	G	H	I	L	M	N	Weight (g)
040724	FL32ALUN	32	32	65	80	32	50	6,6	11	7	10	6,4	14	32	88
040725	FL40ALUN	40	42	82	102	42	60	6,6	11	9	10	6,4	14	36	143
040726	FL50ALUN	50	50	90	110	50	68	9	15	9	12	8,6	18	45	204
040727	FL63ALUN	63	62	110	130	62	87	9	15	9	15	8,6	18	50	411
040728	FL80ALUN	80	82	135	160	82	107	11	18	12	15	10,6	23	63	616
040729	FL100ALUN	100	103	163	190	103	128	11	18	14	15	10,6	28	75	890

For rear 90° hinge use:

- from bore 12 to 25 mm
- from bore 32 to 100 mm

Rear clevis ISO 6432, type **CF** (see page 1.95.1).

Rear 90° hinge VDMA, type **ASV** (see page 1.97.2).