

FILTER HOUSING – AAF

O₂ - Oxygen

DESCRIPTION

AAF O₂ series of filter housings have been specifically developed for high efficient removal of solid particles from compressed Oxygen applications.

APPLICATIONS ⁽¹⁾

- General industrial application
- Medical
- Food and beverage
- Petrochemical
- Waste water treatment



⁽¹⁾ AAF O2 filter housing can be used in variety of applications. For applications not listed please contact us or your local dealer.

TECHNICAL SPECIFICATION

Operating temperature	1,5 - 65 °C	35 - 149 °F
Operating pressure	0 - 16 bar(g)	0 - 232 psi

MATERIALS

Housing material	Aluminium
Fittings, Screws	Brass, Brass-zinc plated, Steel
Cover	PA6
Sealing	FKM
Corrosion protection	Electrophoretic Coating (KTL)
Outside protection	Powder paint coated (Epoxy-polyester base)
Lubricant	Berulub OX 40 EP (Oxygen compatible)

SIZES

FILTER HOUSING	PIPE SIZE [inch]	FILTER ELEMENT	FLOW CAPACITY		DIMENSIONS [mm]				VOLUME [l]	WEIGHT [kg]
			[Nm ³ /h]	[scfm]	A	B	C	D		
AAF 0006 O2	1/8	03528	10	6	105	55	14	50	0,07	0,23
AAF 0016 O2	1/4	05528	18	11	125	55	14	70	0,09	0,24
AAF 0026 O2	1/4	03844	25	15	145	73	18	50	0,22	0,42
AAF 0036 O2	3/8	03844	30	18	145	73	18	50	0,22	0,42
AAF 0046 O2	1/4	06050	35	22	189	88	32	60	0,44	0,72
AAF 0056 O2	3/8	06050	60	35	189	88	32	60	0,45	0,71
AAF 0076 O2	1/2	07050	78	46	189	88	32	80	0,45	0,70
AAF 0106 O2	3/4	14050	120	70	257	88	32	150	0,64	0,78
AAF 0186 O2	1	12075	198	116	261	125	37	160	1,4	1,9
AAF 0306 O2	1	22075	335	197	361	125	37	250	2,0	2,4
AAF 0476 O2	1 1/2	32075	510	300	461	125	37	350	2,6	2,6
AAF 0706 O2	1 1/2	50075	780	459	641	125	37	530	3,6	3,5

Flow capacity at 7 bar(g), 20°C
Standard is BSP pipe connection, other pipe connection on request.

PRESSURE EQUIPMENT DIRECTIVE PED 2014/68/EU (Fluid group 1)

AAF O2 0006 – AAF O2 0186	Article 4.3
AAF O2 0306 – AAF O2 0476	Category 1, Module H
AAF O2 0706	Category 2, Module H

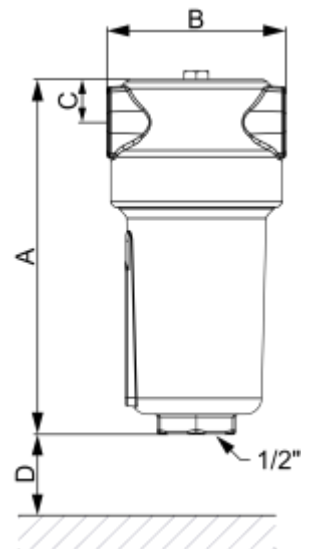

CORRECTION FACTORS

To calculate the correct capacity of a given filter based on actual operating conditions, multiply the nominal flow capacity by the appropriate correction factor(s).

CORRECTED CAPACITY = NOMINAL FLOW CAPACITY x C_{OP}

OPERATING PRESSURE

[bar]	2	3	4	5	6	7	8	9	10	11	12	13	14	15	16
[psi]	29	44	58	72	87	100	115	130	145	160	174	189	203	218	232
C _{OP}	0,38	0,5	0,63	0,75	0,88	1	1,13	1,25	1,38	1,50	1,63	1,75	1,88	2,00	2,13

MAINTENANCE

Replace filter element at least every 12 months or follow the instructions for specific filter element. Once per year make a visual check of filter housing and make sure there is no visual damage.

Warning – Use oxygen compatible lubricant grease only!

INFORMATION IN THIS DOCUMENT IS SUBJECT TO CHANGE WITHOUT NOTICE

	Our quality management system is certified by BUREAU VERITAS in conformity with ISO 9001:2015 Reg. number: SL22594Q
---	--