

# ACTIVATED CARBON TOWER TAC F



## DESCRIPTION

TAC F activated carbon towers have been developed for separating oil vapours from compressed air<sup>(1)</sup> (dry type separation). TAC F series is made from high quality carbon steel. Flow distributors ensure uniform distribution of air flow through activated carbon bed. Oil vapours as well as some other hydrocarbons are separated due to adsorption process. Super fine coalescing filter is required upstream TAC F and 1µm dust filter is recommended downstream to intercept activated carbon dust.

## APPLICATIONS<sup>(2)</sup>

- Automotive
- Electronics
- Food & Beverage
- Chemical
- Petrochemical
- Plastics
- Paint
- General industrial application

<sup>(1)</sup>For any other technical gas please contact us or your local dealer

<sup>(2)</sup>TAC F can be used in variety of applications. For applications not listed please contact us or your local dealer.

## ACTIVATED CARBON TOWER RATING ACCORDING TO ISO8573-1

Solid particles	Water	Oil
-	-	0 / 1

## TECHNICAL SPECIFICATION

Operating temperature	1,5 - 50 °C	35 – 122 °F
Operating pressure	0 - 16 bar(g)	0 - 232 psi
Differential pressure	Approx. 100mbar	0,29 psi
Oil vapour content (nominal) <sup>(3)</sup>	< 0,003 mg/m <sup>3</sup>	

<sup>(3)</sup>at inlet concentration < 0,01 mg/m<sup>3</sup>, liquid content should be removed in advance by fine coalescing filtration

## MATERIALS

Housing material	Carbon steel
Fittings, Screws	Brass, Brass-zinc plated, Steel
Sealing	Teflon + Klingerit
Corrosion protection (internal)	Hot-dip galvanizing (on request)
Outside protection	Powder paint coated (Epoxy-polyester base)
Lubricant	Shell cassida grease RLS 2

**SIZES**

ADSORBER HOUSING	CONN. SIZE <sup>(5)</sup>	FLOW CAPACITY <sup>(4)</sup>		DIMENSIONS			ACTIVATED CARBON [kg]	VOLUME [l]	WEIGHT [kg]
		[m <sup>3</sup> /h]	[scfm]	A[mm]	B[mm]	C[mm]			
TAC 1200 F	DN 50	1200	936,0	2070	550	590	95	215	280
TAC 1500 F	DN 65	1500	1170	2110	620	650	119	270	355
TAC 2000 F	DN 65	2000	1560	2195	700	750	165	400	420
TAC 2500 F	DN 80	2500	1950	2235	760	800	192	470	510
TAC 3000 F	DN 80	3000	2340	2305	900	860	224	550	595
TAC 3750 F	DN 100	3750	2925	2370	800	970	296	730	745
TAC 5000 F	DN100	5000	3900	2500	950	1100	373	950	960
TAC 6500 F	DN 125	6500	5070	2575	1100	1210	554	1270	1300

<sup>(4)</sup>Refers to 1bar(a) and 20°C at 7 barg operating pressure and inlet temperature 20°C

<sup>(5)</sup>Standard connections: inlet top left, outlet bottom right

**PRESSURE EQUIPMENT DIRECTIVE PED 2014/68/EU (Fluid group 2)**

TAC 1200 F – TAC 6500 F Category 4, Module H1

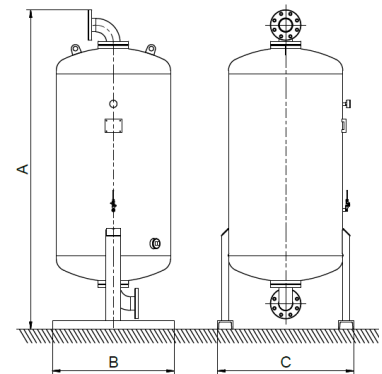

**CORRECTION FACTORS**

To calculate the correct capacity of a given tower based on actual operating conditions, multiply the nominal flow capacity by the appropriate correction factor(s).

CORRECTED CAPACITY = NOMINAL FLOW CAPACITY x C<sub>OP</sub> x C<sub>OT</sub>

**OPERATING PRESSURE**

[bar]	2	3	4	5	6	7	8	9	10	11	12	13	14	15	16
[psi]	29	44	58	72	87	100	115	130	145	160	174	189	203	218	232
C <sub>OP</sub>	0,38	0,5	0,63	0,75	0,88	1	1,13	1,25	1,38	1,50	1,63	1,75	1,88	2,0	2,13

**OPERATING TEMPERATURE**

[°C]	20	25	30	35	40	45	50
C <sub>OT</sub>	1	0,98	0,97	0,92	0,86	0,75	0,6

**MAINTENANCE**

Replace activated carbon every 12 months or sooner if required. Check residual oil content with oil indicator monthly.

INFORMATION IN THIS DOCUMENT IS SUBJECT TO CHANGE WITHOUT NOTICE

	Our quality management system is certified by BUREAU VERITAS in conformity with ISO 9001:2015 Reg. number: 200285
--	--