



4 to 16 bar
operating pressure

1,5 to 60°C
inlet air temperature range

-40°C (-25°C / -70°C)
pressure dew points

1200 to 6500 Nm³/h
flow rate

RAL 5012
standard colour

15-20%
avg. comp. air consumption

DESCRIPTION

F-DRY adsorption dryers are designed for continuous separation of water vapour from the compressed air thus reducing pressure dew point. F-DRY series dryer consists of two columns, filled with desiccant beds, controller with LCD display, valves, manometers, support construction and suitable filter housings with the required filter element. Adsorption takes place under pressure in the first column while the second column regenerates with a portion of already dried compressed air at ambient pressure. When the first column is saturated to a certain level column switch-over is carried out and the process of adsorption continues in the second column without any drop of pressure at the outlet of the dryer. Regeneration of saturated desiccant is possible because a small portion of already dry compressed air is decompressed and when expanded it becomes extremely dry.

APPLICATIONS

- Compressed air systems

F-DRY SERIES

HEATLESS REGENERATION ADSORPTION COMPRESSED AIR DRYERS

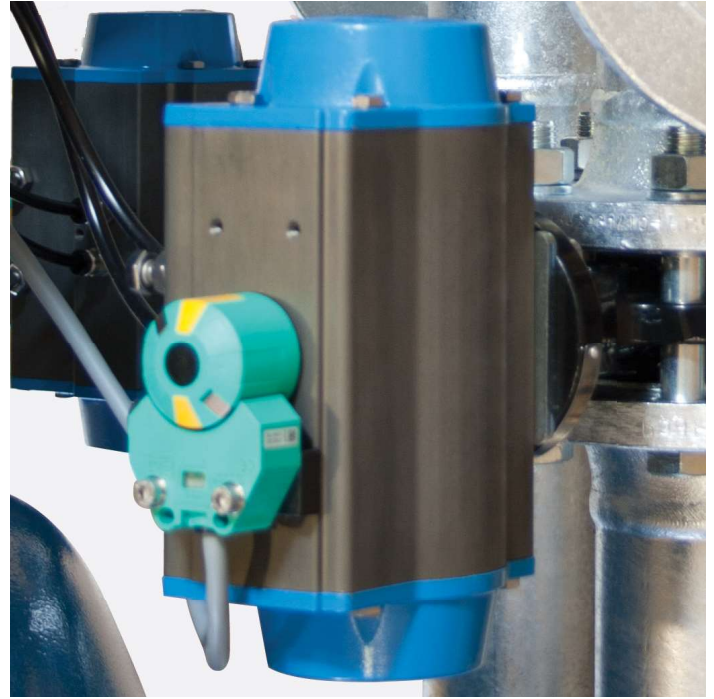

TECHNICAL DATA

Type	Connection IN/OUT	Nominal volume flow		Dimensions			Mass
		Inlet ¹	Outlet ²	A [mm]	B [mm]	C [mm]	
	DN	[Nm ³ /h]	[Nm ³ /h]				kg
F-DRY 1200	DN50	1200	936	1210	850	2170	820
F-DRY 1500	DN65	1500	1170	1535	950	2210	980
F-DRY 2000	DN65	2000	1560	1685	980	2330	1550
F-DRY 2500	DN80	2500	1950	1785	1120	2260	1680
F-DRY 3000	DN80	3000	2340	1875	1120	2400	1850
F-DRY 3750	DN100	3750	2925	2025	1230	2490	2300
F-DRY 5000	DN100	5000	3900	2235	1230	2600	2850
F-DRY 6500	DN125	6500	5070	2420	1430	2730	3750

Voltage, frequency	230V, 50/60 Hz
Power consumption	<60 W
Protection class	IP 65
Filter (inlet)*	super fine - 0,01 µm
Filter (outlet)	dust filter; 1 µm
DPD control	optional
Input for stand-by	standard

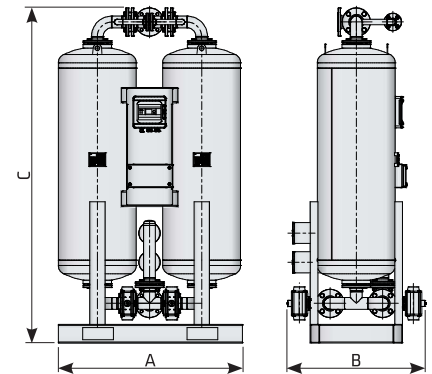
OPERATING PRESSURE - CORRECTION FACTORS - C_{OP}

Operating pressure [bar]	4	5	6	7	8	9	10	11	12	13	14	15	16
Operating pressure [psi]	58	72	87	100	115	130	145	160	174	189	203	218	232
Correction factor C _{OP}	0,63	0,75	0,88	1	1,13	1,25	1,38	1,50	1,63	1,75	1,88	2,00	2,13

OPERATING TEMPERATURE - CORRECTION FACTORS - C_{OT}

Operat. temperature [°C]	25	30	35	40	45	50	55	60
Operat. temperature [F]	77	86	95	104	113	122	131	140
Correction factor C _{OT}	1	1	1	0,97	0,87	0,80	0,64	0,51

DEW POINT - CORRECTION FACTORS - C_D

Operat. temperature [°C]	-25	-40	-70
Operat. temperature [F]	-13	-40	-94
Correction factor C _D	1,1	1	0,7

⁽¹⁾ Refers to 1bar(a) and 20°C at 7 bar operating pressure, inlet temperature 35°C and pressure dew point at outlet -40°C.

⁽²⁾ Outlet flow refers to typical assumption during regeneration phase for operating at nominal inlet flow conditions. Outlet flow includes average air losses of approximately 17,3 %.

* If dryer is supplied without inlet filter compressed air class 1 (ISO 8753-1) for solid particles and oil should be provided to the inlet of the dryer.