



R-DRY BVA SERIES

VACUUM REGENERATION WITH AMBIENT AIR

4 to 11 bar
operating pressure

1,5 to 42,5°C
inlet air temperature range

-40°C
pressure dew points

390 to 20.200 Nm³/h
flow rate

0 %
avg. comp. air consumption

DESCRIPTION

R-DRY BVA 400-20000 adsorption dryers are designed for continuous separation of water vapour from compressed air thus lowering the dew point.

R-DRY BVA dryers have two columns that operate alternately. Adsorption takes place under pressure in the first column while the second column regenerates (heated ambient air for desorption + ambient air in vacuum mode for cooling). BVA type of dryer is suitable for applications running at mild ambient conditions. Due to regeneration in vacuum mode BVA type of dryers don't consume any compressed air for the operation.

A dryer consists of two columns, filled with desiccant beads, a blower, heater, controller with an LCD display, valves, manometers, and a support construction. A proven and robust design enables efficient and reliable operation, fast installation and simple maintenance.

APPLICATIONS

- Compressed air systems



- A1-2 pressure vessel
- F1 inlet filter (super fine coalescing)
- F2 outlet filter (dust)
- V1-6 ball valve with pneumatic actuator
- V7-10 angle seated valve with pneumatic actuator
- CV1-2 check valve
- TT1-4 temperature transducer
- PI1-2 pressure indicator
- PT11-2 pressure transducer
- DT1 dewpoint transducer
- M1 blower
- H1 heater
- F3 regeneration air filter
- GI air inlet
- GO air outlet
- RI regeneration air inlet
- RO regeneraton air outlet
- ES1-2 ekspansion silencer

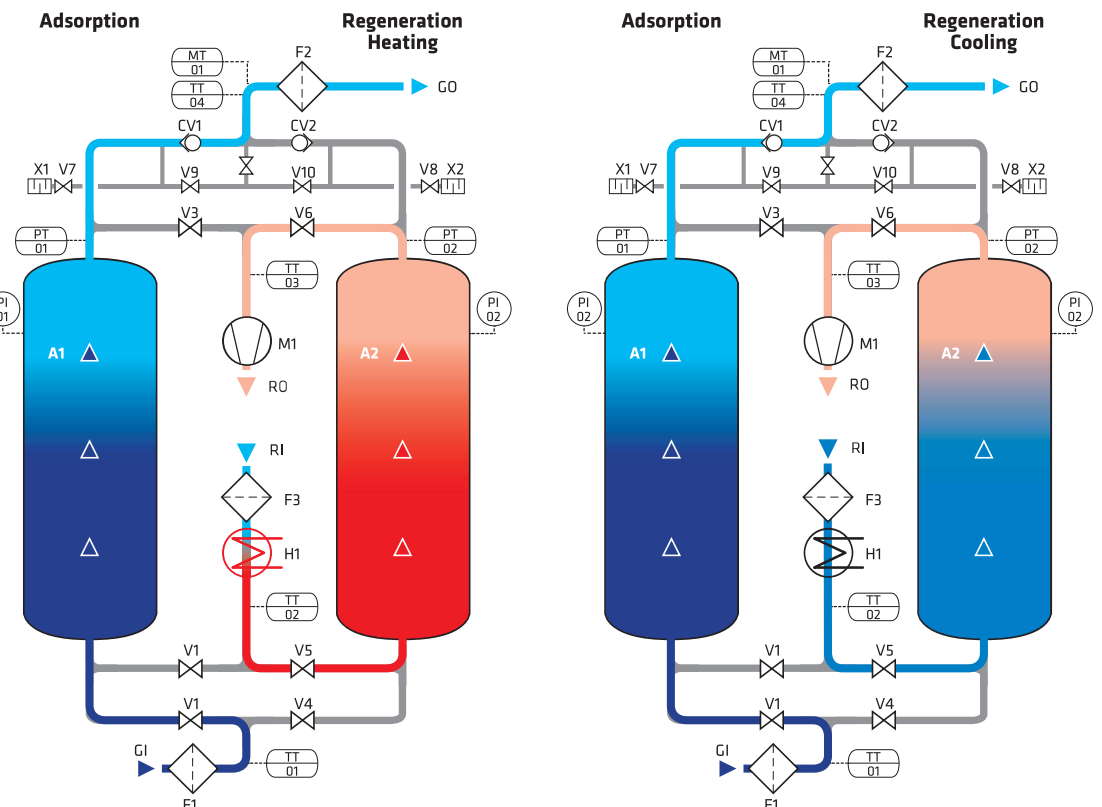



TECHNICAL DATA									
Type	Connection IN/OUT ⁽²⁾	Nominal volume flow Inlet ⁽¹⁾	Dimensions			Mass kg	Blower power kW	Heater power kW	Filter type
			DN	[Nm ³ /h]	A [mm]				
R-DRY 400 BVA	DN50	390	1.200	850	2.250	1000	1,3	3,5	AF 0476
R-DRY 600 BVA	DN50	590	1.500	900	2.350	1400	1,6	5,5	AF 0706
R-DRY 780 BVA	DN50	780	1.750	1.000	2.450	1800	1,6	7	AF 0706
R-DRY 1000 BVA	DN50	930	1.750	1.250	2.450	1900	1,6	8	AF 0946
R-DRY 1200 BVA	DN80	1.150	1.900	1.100	2.450	2200	1,6	10	AF 1506
R-DRY 1600 BVA	DN80	1.600	1.900	1.350	2.500	2600	4	14	AF 1756
R-DRY 2000 BVA	DN100	1.950	2.200	1.150	2.600	3400	4	17	AF 2006
R-DRY 2500 BVA	DN100	2.530	2.350	1.150	2.750	3800	7,5	22	AF 2406
R-DRY 3000 BVA	DN100	2.990	2.500	1.150	2.750	4000	8,5	26	BF 300
R-DRY 3600 BVA	DN100	3.680	2.800	1.350	2.850	4800	8,5	32	BF 450
R-DRY 4100 BVA	DN125	4.100	3.000	1.350	2.850	5100	8,5	35	BF 450
R-DRY 5000 BVA	DN125	4.990	3.200	1.450	2.950	5900	15	45	BF 600
R-DRY 6500 BVA	DN150	6.550	3.520	1.750	3.050	7200	15	56	BF 900
R-DRY 7700 BVA	DN150	7.700	3.700	2.000	3.100	7900	15	70	BF 900
R-DRY 10000 BVA	DN200	10.250	4.300	2.200	3.550	12000	22	95	BF 1200
R-DRY 12000 BVA	DN200	11.700	4.400	2.500	3.550	14200	-	-	BF 1200
R-DRY 14000 BVA	DN200	14.800	4.800	2.600	3.650	16800	-	-	BF 1500
R-DRY 16000 BVA	DN250	16.000	5.000	3.200	3.650	18500	-	-	BF 1800
R-DRY 18000 BVA	DN250	18.200	5.200	3.500	4.200	20000	-	-	BF 1800
R-DRY 20000 BVA	DN250	20.200	6.000	3.500	4.350	23000	-	-	BF 2500

OPERATING PRESSURE - CORRECTION FACTORS - C _{OP}								
Operating pressure [bar]	4	5	6	7	8	9	10	11
Operating pressure [psi]	58	72	87	100	115	130	145	160
Correction factor C _{OP}	0,63	0,75	0,88	1	1,13	1,25	1,38	1,50

OPERATING TEMPERATURE - CORRECTION FACTORS - C _{OT}					
Operat. temperature [°C]	25	30	35	40	42,5
Operat. temperature [F]	77	86	95	104	108
Correction factor C _{OT}	1	1	1	0,7	0,52

⁽¹⁾ Refers to 1bar(a) and 20°C at 7 bar operating pressure, inlet temperature 35°C and pressure dew point at outlet -40°C

⁽²⁾ Refers to dryer inlet and outlet connection without filters

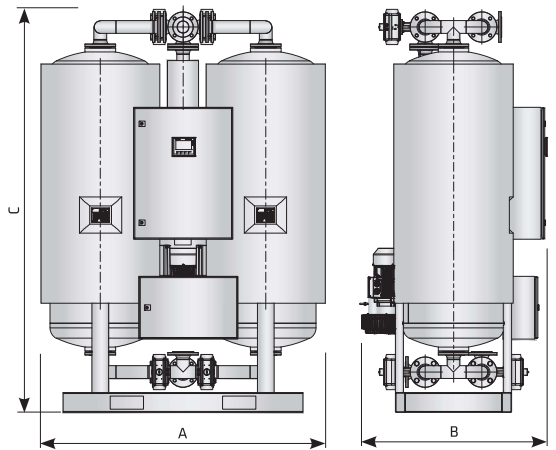

Protection class	IP 54
Filter (inlet)	super fine - 0,01 µm
Filter (outlet)	dust filter; 1 µm
Column insulation	optional
Blower suction conditions	Max 40°C, 25% RH