



**4 to 16 bar**  
operating pressure

**1,5 to 50°C**  
inlet air temperature range

**-40°C (-25°C / -70°C)**  
pressure dew points

**6 to 200 Nm<sup>3</sup>/h**  
flow rate

**RAL 9003**  
standard colour

**15-20%**  
avg. comp. air consumption

## DESCRIPTION

A-DRY BI+BM desiccant adsorption dryer has been designed to separate water moisture from compressed air thus reducing the dew point in the system. A-DRY BI+BM is a range of products offering our customers a wide array of dried air solutions with volumetric flow rates ranging from 6 Nm<sup>3</sup>/h to 200 Nm<sup>3</sup>/h.

An innovative new design of A-DRY BI+BM adsorption driers, developed with consideration of our customers, enables fast and reliable installation, use and servicing. Installation is simple with our ready to use controller while minimising the number of parts and motions required for assembly and disassembly makes servicing fast and reliable.

## APPLICATIONS

- Compressed air systems

# A-DRY BI+BM SERIES

## HEATLESS REGENERATION ADSORPTION COMPRESSED AIR DRYERS



## ADVANTAGES

- ✓ Wide range of products to fit your need.
- ✓ Robust and intuitive ready to use controller.
- ✓ Simple assembly and disassembly.
- ✓ Fast and reliable servicing.
- ✓ Adsorbent in cartridges.
- ✓ Standard version includes coalescing prefilter and particle afterfilter.



TECHNICAL DATA

Type	Connection IN/OUT	Nominal volume flow		Dimensions							Mass kg
		Inlet <sup>1</sup>	Outlet <sup>2</sup>	A [mm]	A* [mm]	B [mm]	B* [mm]	C [mm]	C* [mm]	D [mm]	
		[Nm <sup>3</sup> /h]	[Nm <sup>3</sup> /h]								
<b>A-DRY 06 BI</b>	G3/8"	6	4,7	339	520	280	467	100	130	444	10,5
<b>A-DRY 12 BI</b>	G3/8"	12	9,5	573	715	280	467	100	130	444	13,5
<b>A-DRY 24 BI</b>	G3/8"	24	19,0	1041	1105	280	467	100	130	444	19,0
<b>A-DRY 36 BI</b>	G3/8"	36	28,4	1509	1495	280	467	100	130	444	27,5
<b>A-DRY 60 BI</b>	G3/4"	60	47,4	972	1105	370	607	148	170	573	45,0
<b>A-DRY 75 BI</b>	G3/4"	75	59,3	1167	1300	370	607	148	170	573	53,0
<b>A-DRY 105 BI</b>	G3/4"	117	83	1567	1700	370	607	148	170	573	70,0
<b>A-DRY 150 BI</b>	G1"	150	118	1345	1440	440	948	198	240	933	170,5
<b>A-DRY 200 BI</b>	G1"	200	158	1538	1655	440	948	198	240	933	182,2

Operating pressure range	4 to 16 bar(g)
Operating temperature range	+1,5 °C to +50 °C
Pressure dew points	-25 °C / -40 °C / -70 °C
Voltage, frequency	230V, 50/60 Hz
Power consumption	<35 W
Protection class	IP 65
Filter (inlet)*	super fine; 0,01 µm
Filter (outlet)	dust filter; 1 µm

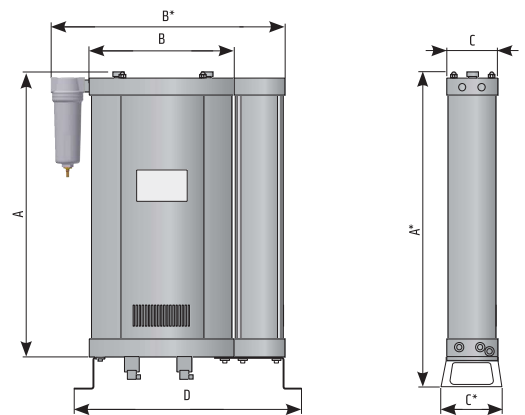

<sup>(1)</sup> Refers to 1bar(a) and 20°C at 7 bar operating pressure, inlet temperature 35°C and pressure dew point at outlet -40°C.  
<sup>(2)</sup> Outlet flow refers to typical assumption during regeneration phase for operating at nominal inlet flow conditions. Outlet flow includes average air losses of approximately 17,3 %.  
 \* If dryer is supplied without inlet filter compressed air class 1 (ISO 8753-1) for solid particles and oil should be provided to the inlet of the dryer.

CORRECTION FACTORS - F1

Operating pressure [bar]	4	5	6	7	8	9	10	11	12	13	14	15	16
Operating pressure [psi]	58	72	87	100	115	130	145	160	174	189	203	218	232
Correction factor	0,63	0,75	0,88	1	1,13	1,25	1,38	1,50	1,63	1,75	1,88	2,00	2,13

CORRECTION FACTORS - F2

Inlet temperature [°C]	25	30	35	40	45	50
Correction factor	1,00	1,00	1,00	0,97	0,87	0,80

DEW POINT

[°C]	-25	-40	-70
C <sub>0</sub>	1,1	1	0,7