

Standard executions			
Version	Symbol	Code	Item
Electric Flip-flop		033170	AEF1520
Pneumatic Flip-flop		033160	APF1520

II 2Gc IIB T5
II 2Dc T100°C

On request, they can be supplied according to 2014/34/EU - ATEX



Series of Flip-flop electrically or pneumatically operated.

Flip-flop: Circuit composed by a 1/4" power valve 5/2 two stable position. With the same signal applied twice at different times the cylinder carries out a complete cycle.

Coils and connectors have to be ordered separately.

For the coils type ASA12.. see page 2.200.1.
 For the connectors type A12209.. see page 2.210.20.

Standard executions			
Version	Symbol	Code	Item
Electric continuous cycling		033172	AEC1520
Pneumatic continuous cycling		033171	APC1520



Series of integrated circuits, electrically or pneumatically operated.

Continuous cycling: Circuit composed by a 1/8" power valve 5/2 single stable position. Keeping the signal the cylinder carries out continuous cycling till the signal is not interrupted.

Coils and connectors have to be ordered separately.

For the coils type ASA12.. see page 2.200.1.
 For the connectors type A12209.. see page 2.210.20.

Technical data		
Fluid	Compressed filtered air with or without lubrication. Lubrication, if started, must be continued.	
Pressure range	25 bar	
Temperature range	-10 °C ÷ + 60°C	
Orifice	6 mm	8 mm
Flow	800 NI/min	1200 NI/min
Manual override	Two stable position, flat	
Response time	Energising: 20 ms	De-energising: 38 ms
Mounting	In any position	
Materials	Body:	Anodised aluminium
	Base:	Anodised aluminium
	Seals:	Hydrogenated Nitrile Butadiene Rubber (HNBR)

Type: **APF1520**

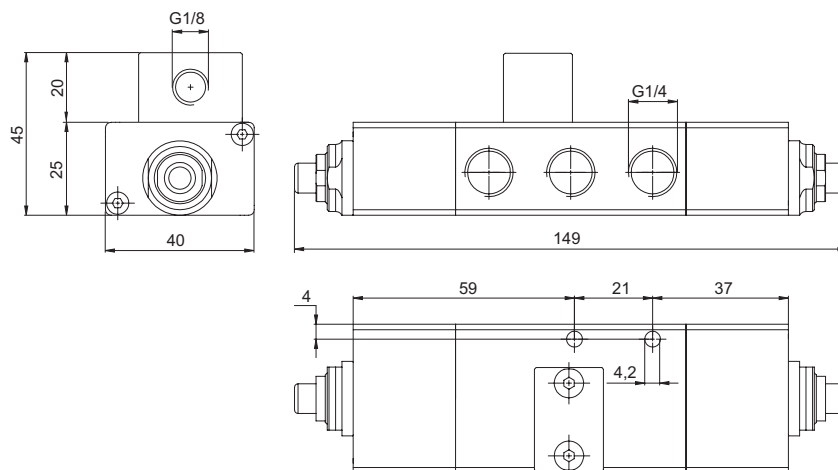

Type: **AEF1520**

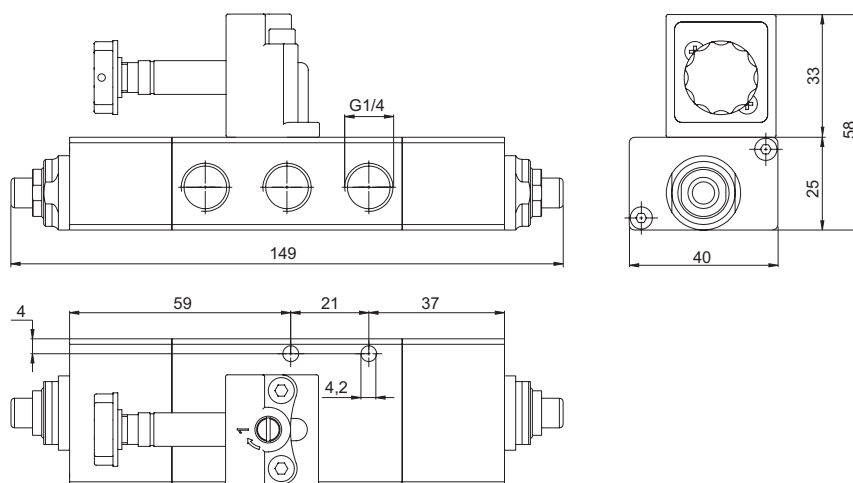

Type: **APC1520**

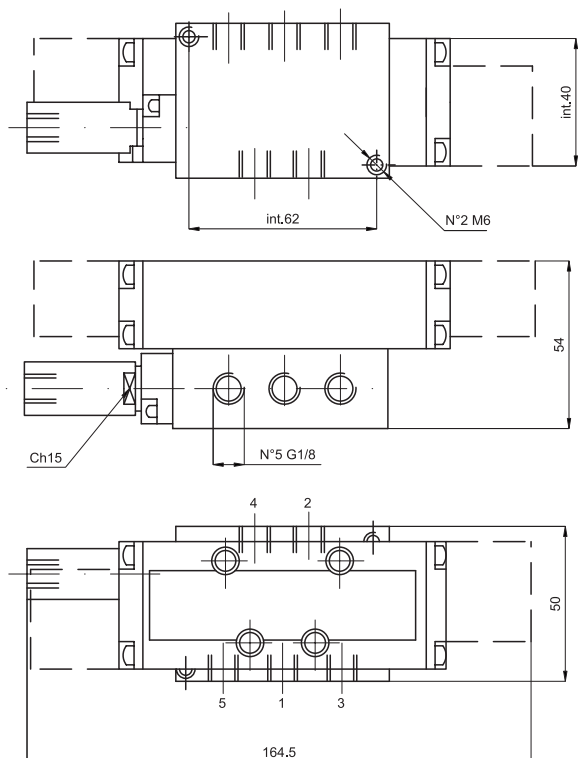

Type: **AEC1520**

