

Mounting Accessories for Cylinders

Mountings for CNOMO in aluminium



Standard executions		
Version	Sym.	Type
Rear clevis		CF..ALCN
Rear standard hinge		AN..ALCN
Rear 90° hinge		AS..ALCN
High foot		P..ALCN
Wide high foot		PL..ALCN



Technical data	
Material	Die-cast aluminium
Treatment	Sifting

Note: The mounting screws are to be ordered separately.
For screws see page 1.101.1.

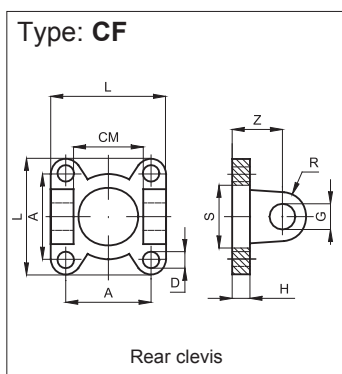

Code	Item	For cyl. Ø mm	A	L	D	H	CM	S	R	Z	G	Weight (g)
040401	CF32ALCN	32	33	45	7	8	26	25	8	18	8	38
040402	CF40ALCN	40	40	52	7	8	33	32	12	24	12	58
040403	CF50ALCN	50	49	65	9	10	33	32	12	26	12	118
040404	CF63ALCN	63	59	75	9	10	47	45	16	30	16	146
040405	CF80ALCN	80	75	95	11	12	47	45	16	32	16	324
040406	CF100ALCN	100	90	115	11	12	57	55	20	37	20	492
040407	CF125ALCN	125	110	140	14	16	57	55	21	41	20	978
040408	CF160ALCN	160	140	180	18	20	72	65	25	55	25	1872
040409	CF200ALCN	200	175	220	18	20	72	65	25	55	25	2800

The pin is to be ordered separately: for the pin see page 1.99.50 (SEC..AQC�N)

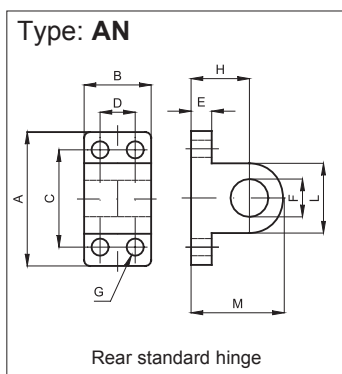

Code	Item	For cyl. Ø mm	A	B	C	D	E	F	G	H	L	M	Weight (g)
040281	AN32ALCN	32	40	25	28	-	8	8	7	18	16	26	26
040282	AN40-50ALCN	40-50	52	32	38	16	10	12	9	26	24	38	56
040284	AN63-80ALCN	63-80	75	46	54	25	12	16	11	34	36	52	176
040286	AN100-125ALCN	100-125	115	56	90	32	16	20	14	41	40	61	376
040288	AN160-200ALCN	160-200	180	71	150	43	20	25	18	55	50	80	924

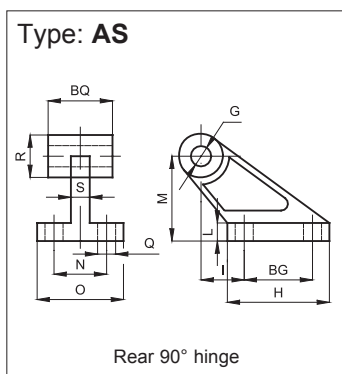

Code	Item	For cyl. Ø mm	Q	BG	H	I	L	M	N	O	S	R	BQ	G	Weight (g)
040321	AS32ALCN	32	7	20	37	18	8	32	25	41	9	19,5	25	8	58
040322	AS40-50ALCN	40-50	9	32	54	25	10	45	32	52	14	26	32	12	144
040324	AS63-80ALCN	63-80	11	50	75	32	13	63	40	63	14	32	46	16	300
040326	AS100-125ALCN	100-125	14	70	103	40	17	90	50	80	22	42	56	20	694
040328	AS160-200ALCN	160-200	18	110	154	50	20	140	63	111	26	54	70	25	1922



Mounting Accessories for Cylinders

Mounting for CNOMO in aluminium



Type: P

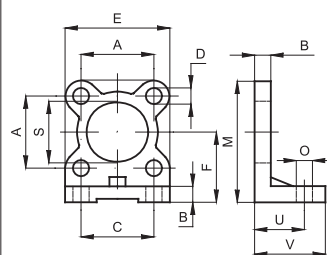

High foot

It is supplied singly.

Code	Item	For cyl. Ø mm	A	B	C	D	E	F	M	O	S	U	V	Weight (g)
040101	P32ALCN	32	33	8	28	7	45	32	54	9	25	27	35	54
040102	P40ALCN	40	40	8	36	7	52	36	62	9	32	27	35	70
040103	P50ALCN	50	49	10	45	9	65	45	77	11	32	35	45	150
040104	P63ALCN	63	59	10	55	9	75	50	87	11	45	35	45	170
040105	P80ALCN	80	75	12	70	11	95	63	110	14	45	43	55	354
040106	P100ALCN	100	90	12	90	11	115	73	130	14	55	43	55	470
040107	P125ALCN	125	110	16	110	14	140	91	161	18	55	52	68	918
040108	P160ALCN	160	140	20	130	18	180	115	205	22	65	62	82	2300
040109	P200ALCN	200	175	20	170	18	220	135	245	22	65	62	92	3450

Type: PL

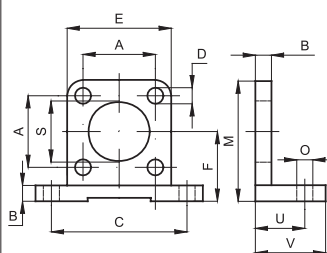

Wide high foot

It is supplied singly.

Code	Item	For cyl. Ø mm	A	B	C	D	E	F	M	O	S	U	V	Z	Weight (g)
040301	PL32ALCN	32	33	8	65	7	46	32	54	9	25	18	35	82	76
040302	PL40ALCN	40	40	8	72	7	52	36	62	9	32	18	35	90	90
040303	PL50ALCN	50	49	10	90	9	65	45	77	11	32	22	45	110	188
040304	PL63ALCN	63	59	10	100	9	75	50	87	11	45	22	45	120	206
040305	PL80ALCN	80	75	12	126	11	95	63	110	14	45	28	55	154	410
040306	PL100ALCN	100	90	12	148	11	115	73	130	14	55	28	55	180	576
040307	PL125ALCN	125	110	16	180	14	140	91	161	18	55	32	67,5	215	1058
040308	PL160ALCN	160	140	20	230	18	180	115	206	22	65	40	80	275	2350
040309	PL200ALCN	200	175	20	270	18	220	135	246	22	65	40	80	318	3100