

Static piston-rod brake for Cylinders ISO 6432

Bores from 20 to 25 mm



Standard executions			
Version	Symbol	Code	Item
Normally closed		042022	ABS 020CRD
		042023	ABS 025CRD
Normally open		042032	ABS 020ARD
		042033	ABS 025ARD



Series of static locking-rod units for cylinders ISO6432. The piston-rod brakes series ABS can be supplied normally closed or normally open.

The main applications are the locking of the piston-rod in the event of a pressure lack or failure or in all those cases where a stop for a machining or handling is necessary.

The clamping forces are suitable for a working pressure of the cylinder equal to 8 bar and act in both directions.

For the application of the piston-rod brake ABS to a cylinder ISO6432 is necessary to order the cylinder with the rod predisposed for this (the extended one in hardened steel, option B, see page 1.5.1).

How to order: ABS020CRD

ABS	020	CRD
Type	Bores	Option

For standard items, codes and dimensions see tables page 1.75.5.

Seal kits not available.

Technical data		
Bores (mm)	20	25
Fluid	Compressed filtered air with or without lubrication.	
Pressure	4 ÷ 8 bar	
Locking force (N)	300	400
Temperature range	-10 °C ÷ +80° C	
Materials	Body:	Anodised aluminium
	Jaws:	Brass
	Seals:	Nitrile rubber (NBR)
	Locking cylinder:	Anodised aluminium

WARNING: working of piston rod-brake type ABS is static: before clamping is necessary to arrest the rod, is not usable for reducing the speed of the rod while moving.

The locking-rod unit must only be unlocked when the pressures of both chambers of the cylinder are balanced, or the rod of the cylinder could move with non-uniform motion, causing problems to the application.

Static piston-rod brake for Cylinders ISO 6432
Bores from 20 to 25 mm



Type: **ABS**

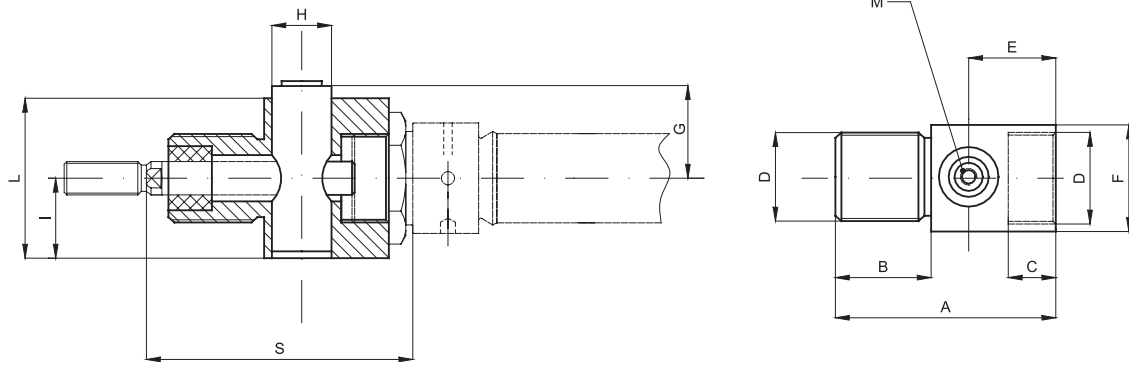

For cylinder Ø mm	A	B	C	E	F	G	H	I	D	L	M	S
20	58	23	12	24	27	21	20	19	M22x1,5	38	M5	72
25	58	23	12	24	27	21	20	19	M22x1,5	38	M5	74