

Parallel Hand Grips with long stroke

Bores from 10 to 32 mm

Double acting



Standard executions		
Version	Code	Item
Bore 10 mm, stroke 20 mm	075037	10/20PPD
Bore 10 mm, stroke 40 mm	075038	10/40PPD
Bore 10 mm, stroke 60 mm	075039	10/60PPD
Bore 16 mm, stroke 30 mm	075040	16/30PPD
Bore 16 mm, stroke 60 mm	075041	16/60PPD
Bore 16 mm, stroke 80 mm	075042	16/80PPD
Bore 20 mm, stroke 40 mm	075044	20/40PPD
Bore 20 mm, stroke 80 mm	075045	20/80PPD
Bore 20 mm, stroke 100 mm	075047	20/100PPD
Bore 25 mm, stroke 50 mm	075048	25/50PPD
Bore 25 mm, stroke 100 mm	075049	25/100PPD
Bore 25 mm, stroke 120 mm	075050	25/120PPD
Bore 32 mm, stroke 70 mm	075051	32/70PPD
Bore 32 mm, stroke 120 mm	075052	32/120PPD
Bore 32 mm, stroke 160 mm	075002	32/160PPD

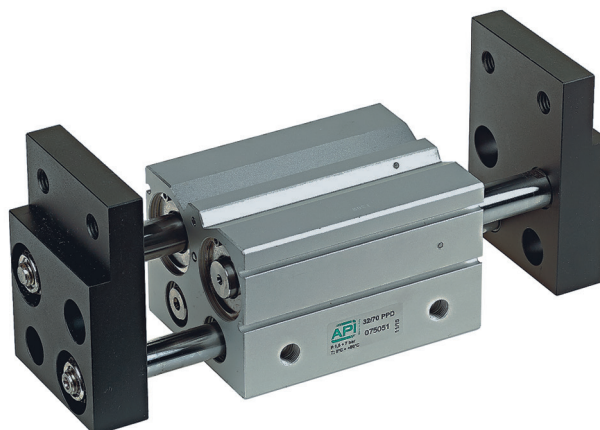

Series of pneumatic parallel hand grips with long stroke available in 5 different sizes.

They are standard magnetic with grooves on the body allowing the direct mounting of magnetic reed switches.

For magnetic reed switch type ASC see from page 1.110.1.

How to order : 25/50PPD

25	/	50	PPD
Bore	/	Stroke	Type

Technical data					
Type	10PPD	16PPD	20PPD	25PPD	32PPD
Fluid	Compressed filtered air with or without lubrication. Lubrication, if started, must be continued.				
Pressure	1,5 ÷ 7 bar				
Temperature range	0 °C ÷ +80° C				
Max. operation frequency	40 cycle / min.				
Lubrication	Piston: with or without lubrication				
	Levers: lubrication is required on moving parts				
Effective gripping force (N)*	14	44	73	128	191
Maximum length of gripping point L (mm)	40	60	80	90	100
Stroke of open/close (mm)	20,40,60	30,60,80	40,80,100	50,100,120	70,120,160
Ports	M5				1/8"

* Gripping point 30 mm at 5 bar

Parallel Hand Grips with long stroke

Bores from 10 to 32 mm

Double acting



Materials

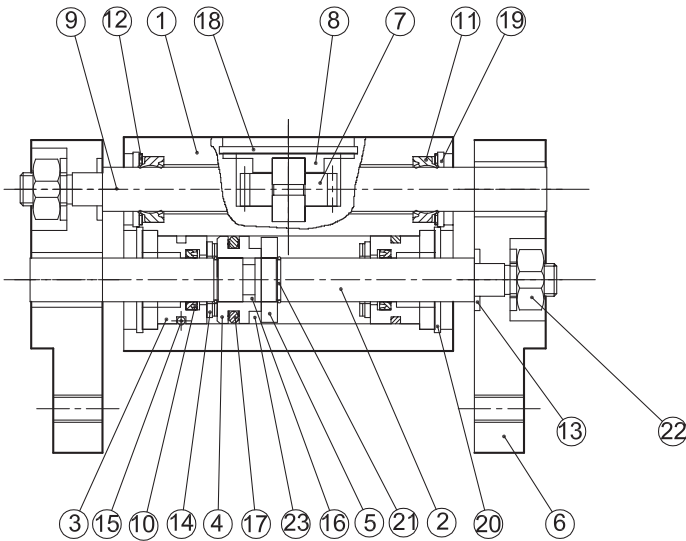

N.	Component	Material
1	Body	Aluminium
2	Piston rod	Stainless steel
3	End cover	Aluminium
4	Piston	Brass
5	Magnet holder	Brass
6	Fingers	Steel alloy
7	Gear rod	Carbon steel
8	Gear cover	Iron
9	Gear	Stainless steel
10	Piston rod seal	NBR
11	Guide rod seal	NBR
12	Seeger	Iron
13	Cushion distancer	Iron
14	Piston rod cushion	Polyurethane
15	End cover O-ring	NBR
16	Piston seal	NBR
17	Piston O-ring	NBR
18	Seeger	Steel
19	Seeger	Steel
20	Seeger	Steel
21	Seeger	Steel
22	Nut	Steel
23	Magnet	Plastic magnet

Type: 10 / .. PPD

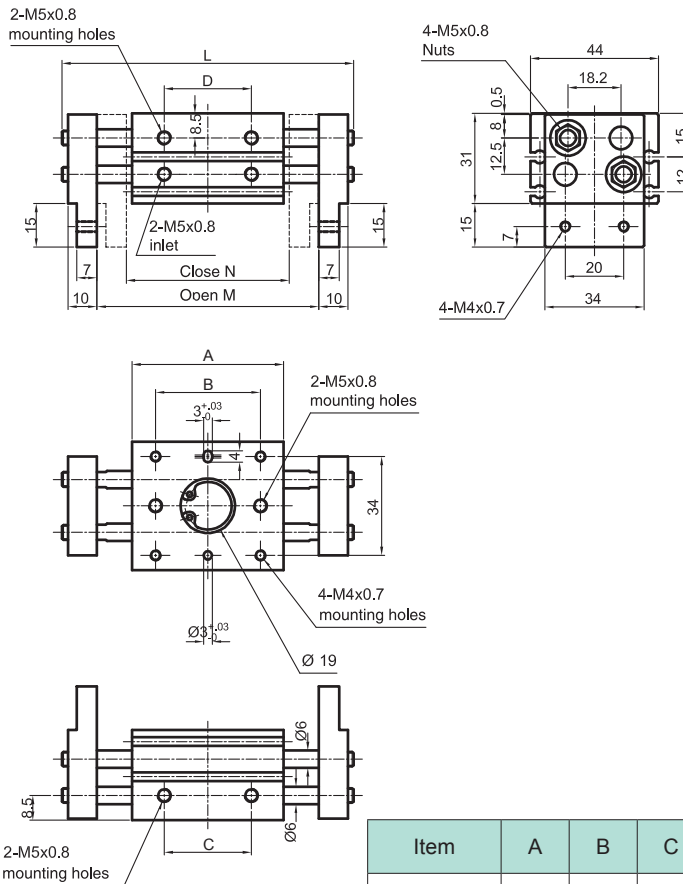

Item	A	B	C	D	L	M	N
10/20PPD	52	36	30	30	100 (80)	76	56
10/40PPD	68	52	46	46	136 (96)	112	72
10/60PPD	86	70	64	64	174 (114)	150	90

Parallel Hand Grips with long stroke

Bores from 10 to 32 mm *Double acting*



Type: 16 / .. PPD

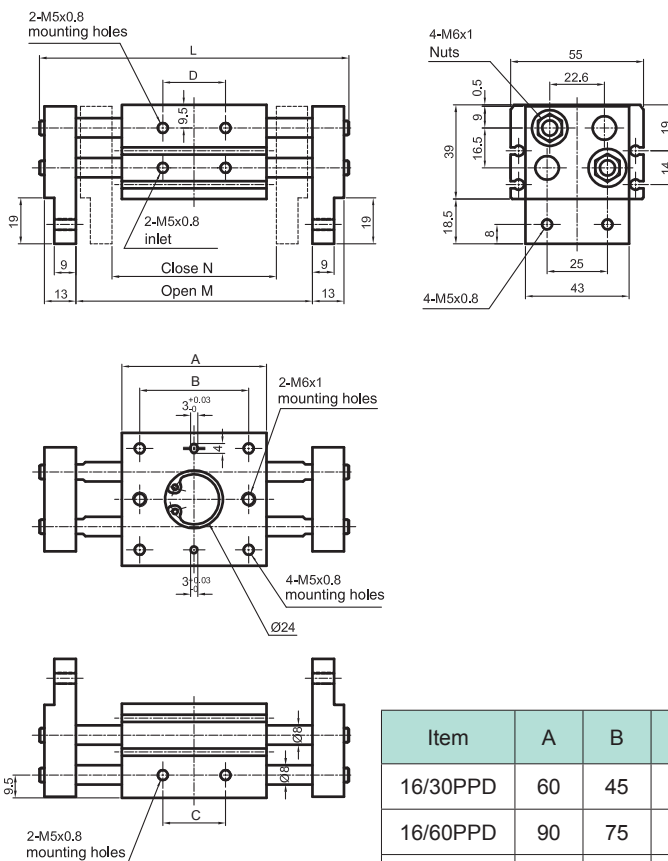

Item	A	B	C	D	L	M	N
16/30PPD	60	45	26	26	128 (98)	98	68
16/60PPD	90	75	56	56	188 (128)	158	98
16/80PPD	110	95	76	76	228 (148)	198	118

Type: 20 / .. PPD

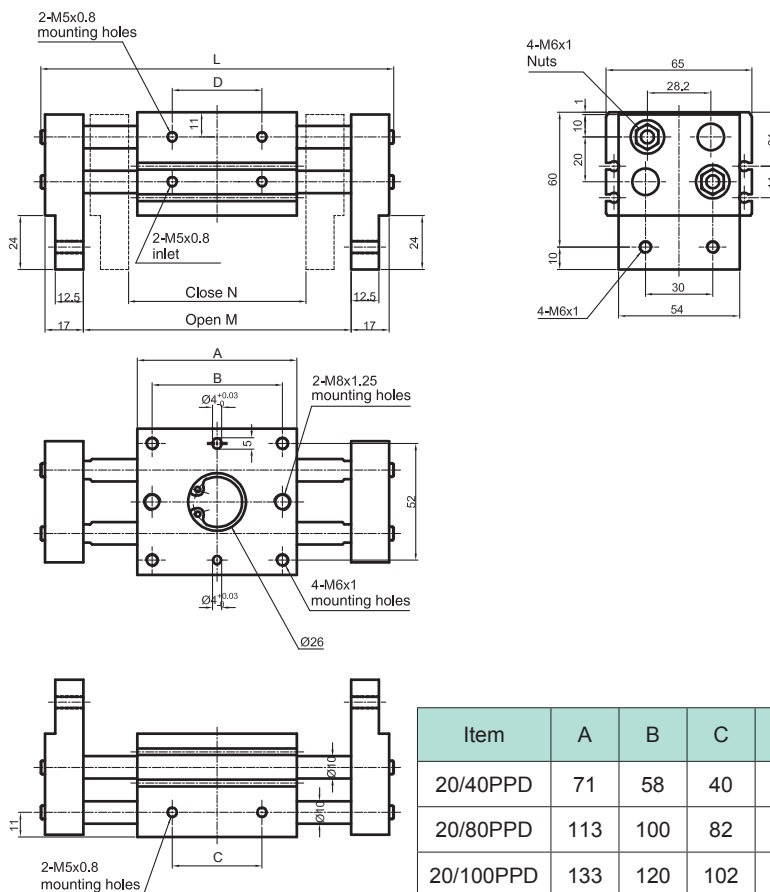

Item	A	B	C	D	L	M	N
20/40PPD	71	58	40	40	157 (117)	119	79
20/80PPD	113	100	82	82	239 (159)	201	121
20/100PPD	133	120	102	102	279 (179)	241	141

Type: 25 / .. PPD

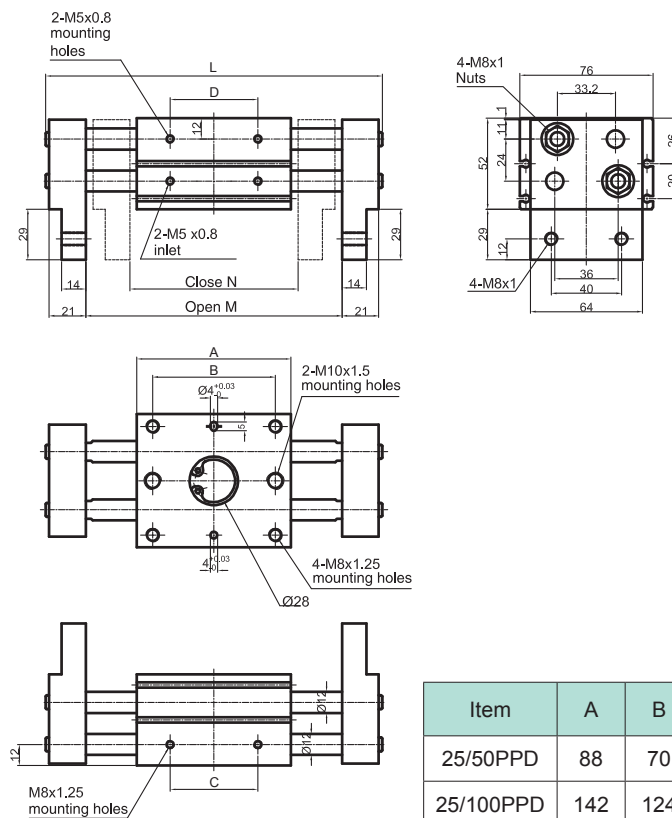

Item	A	B	C	D	L	M	N
25/50PPD	88	70	50	50	192 (142)	146	96
25/100PPD	142	124	104	104	296 (196)	250	150
25/120PPD	160	142	122	122	334 (214)	288	168

Type: 32 / .. PPD

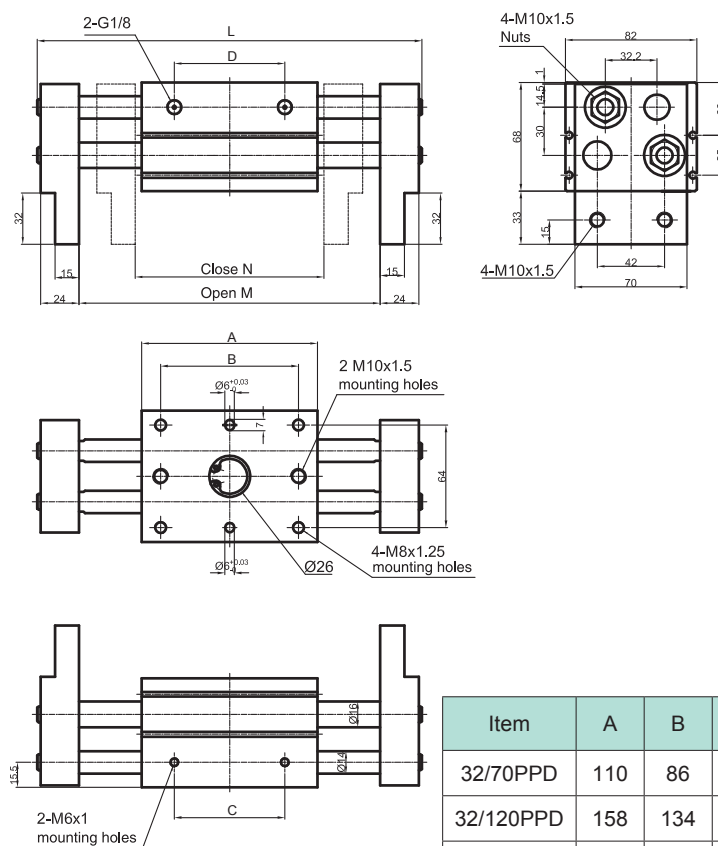

Item	A	B	C	D	L	M	N
32/70PPD	110	86	69	69	240 (170)	188	118
32/120PPD	158	134	117	117	338 (218)	286	166
32/160PPD	202	178	161	161	422 (262)	370	210