

Standard executions		
Version	Symbol	Type
Double acting, magnetic self lubricating bushings		GPB
Double acting, magnetic spherical bushings		GPS



Series of guiding and stopper cylinders, magnetic as standard. This cylinder are made of uni-body aluminium alloy with high anti-rotation, torsion and side load features. Piston with magnet is standard and the body, a one piece, is provided with grooves allowing the mounting of the magnetic reed switch without further brackets; this makes the magnetic sensor not protrude outside the body itself. The bottom plates are provided with elastic cushionings.

For the magnetic reed switches type ASC see from page 1.110.2.

Options	Suffix
Special on request	/ S

How to order: 20/30 GPB

20	/	30	GPB	
Bore	/	Stroke	Type	Option

Technical data								
Fluid	Compressed filtered air with or without lubrication. Lubrication, if started, must be continued.							
Bore	Ø 12	Ø 16	Ø 20	Ø 20	Ø 32	Ø 40	Ø 50	Ø 63
Pressure range	2 ÷ 7 bar							
Temperature range	- 10 °C ÷ + 60 °C							

Bore (mm)	Standard stroke GPB	Standard stroke GPS
12	10, 20, 30, 40, 50, 75, 100	10, 20, 30, 40, 50, 75, 100
16	10, 20, 30, 40, 50, 75, 100	10, 20, 30, 40, 50, 75, 100
20	20, 30, 40, 50, 75, 100, 125, 150, 175	20, 30, 40, 50, 75, 100, 125, 150, 175
25	20, 30, 40, 50, 75, 100, 125, 150, 175	20, 30, 40, 50, 75, 100, 125, 150, 175
32	25, 50, 75, 100, 125, 150	25, 50, 75, 100, 125, 150
40	25, 50, 75, 100, 125, 150	25, 50, 75, 100, 125, 150
50	25, 50, 75, 100, 125, 150	25, 50, 75, 100, 125, 150
63	25, 50, 75, 100, 125, 150	25, 50, 75, 100, 125, 150

Type: **GPB - GPS**
(Bores $\varnothing 12 \div \varnothing 25$)

GPB $\varnothing 12 \div \varnothing 16$

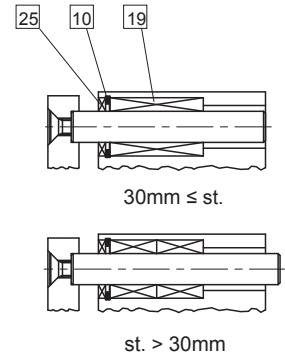
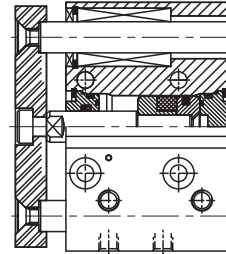
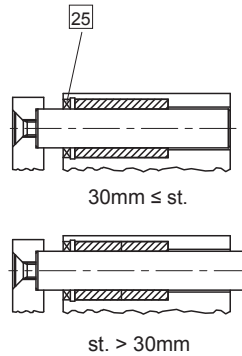
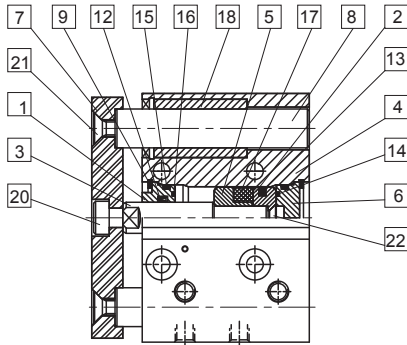

GPB $\varnothing 20 \div \varnothing 25$

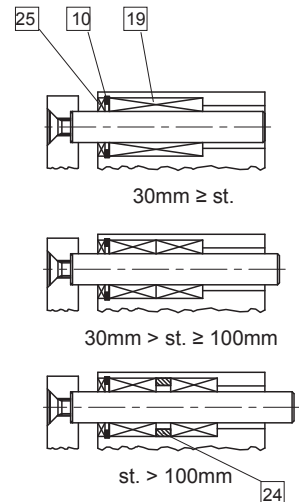
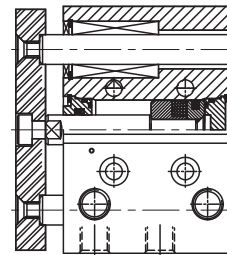
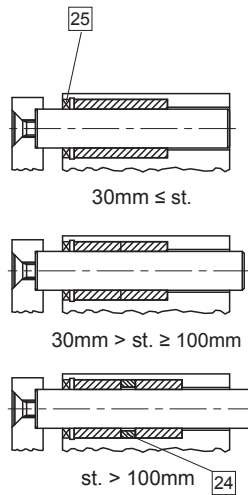
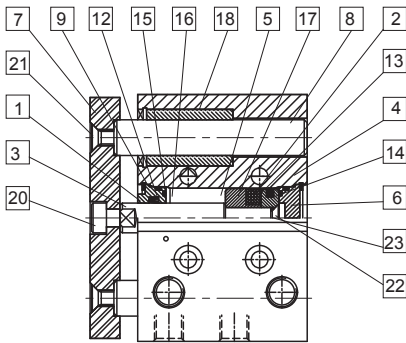

Materials

1	Rod cover	Brass ($\varnothing 12$) - Hard anodised aluminium alloy ($\varnothing 16 \div \varnothing 25$)	14	Rubber lining	Nitrile rubber NBR
2	Piston	Hard anodised aluminium alloy	15	Cylinder gasket	Nitrile rubber NBR
3	Piston rod	Stainless steel ($\varnothing 12$) - Carbon steel ($\varnothing 16 \div \varnothing 32$)	16	Rubber lining	Nitrile rubber NBR
4	Cylinder tube	Hard anodised aluminium alloy	17	Magnet	Magnetic material
5	Magnet holder	Hard anodised aluminium alloy	18	Oilless bearing	Oil-impregnated sintered alloy
6	Head cover	Hard anodised aluminium alloy	19	Linear bearing	Special steel
7	Guide plate	Carbon steel nickel plating	20	Hexagon socket head screw	Carbon steel nickel plating
8	Guide stem	Carbon steel (GPB) - Special steel (GPS)	21	Screw	Carbon steel nickel plating
9	Retaining ring	Carbon steel nickel plating	22	Screw	Carbon steel nickel plating
10	Retaining ring	Carbon steel nickel plating	23	O-ring	Nitrile rubber NBR
11	Oilless bearing	Oil-impregnated sintered alloy	24	Stroke pad	Hard anodised aluminium alloy
12	Rod packing	Nitrile rubber NBR	25	Dust cover	Aluminium alloy ($\varnothing 12 \div \varnothing 16$)
13	Piston packing	Nitrile rubber NBR			Carbon steel - NBR ($\varnothing 20 \div \varnothing 25$)

Type: **GPB - GPS**
(Bores $\varnothing 6 \div \varnothing 32$)

GPB $\varnothing 32 \div \varnothing 63$

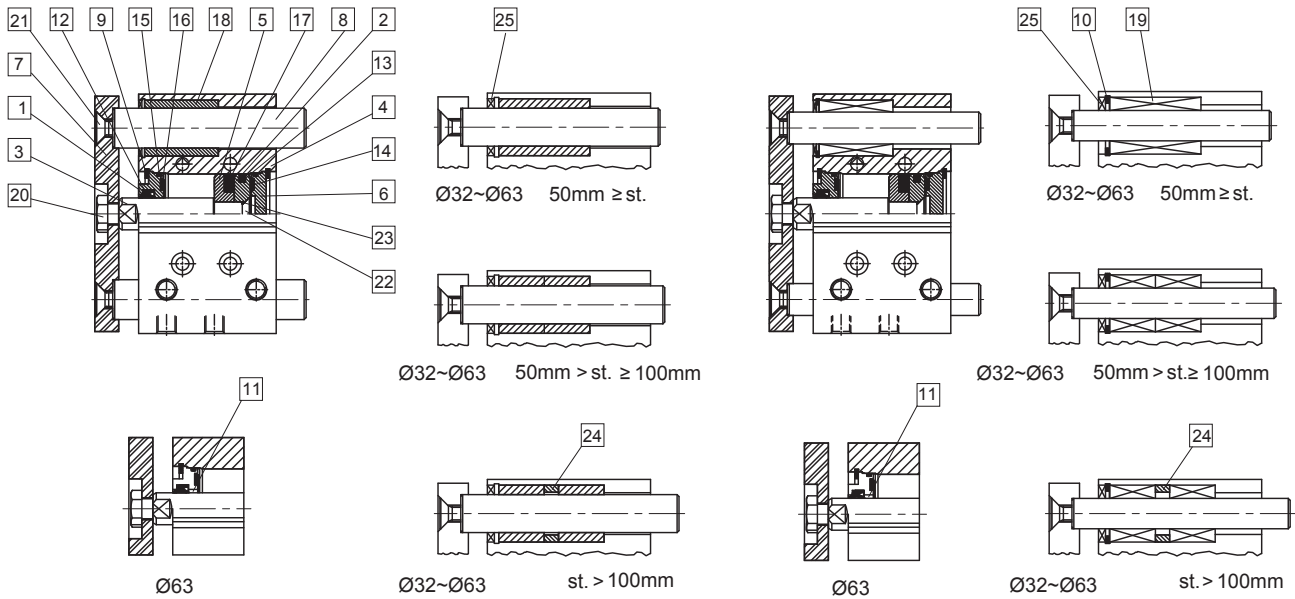

Materials					
1	Rod cover	Brass ($\varnothing 12$) - Hard anodised aluminium alloy ($\varnothing 16 \div \varnothing 25$)	14	Rubber lining	Nitrile rubber NBR
2	Piston	Hard anodised aluminium alloy	15	Cylinder gasket	Nitrile rubber NBR
3	Piston rod	Stainless steel ($\varnothing 12$) - Carbon steel ($\varnothing 16 \div \varnothing 32$)	16	Rubber lining	Nitrile rubber NBR
4	Cylinder tube	Hard anodised aluminium alloy	17	Magnet	Magnetic material
5	Magnet holder	Hard anodised aluminium alloy	18	Oilless bearing	Oil-impregnated sintered alloy
6	Head cover	Hard anodised aluminium alloy	19	Linear bearing	Special steel
7	Guide plate	Carbon steel nickel plating	20	Hexagon socket head screw	Carbon steel nickel plating
8	Guide stem	Carbon steel (GPB) - Special steel (GPS)	21	Screw	Carbon steel nickel plating
9	Retaining ring	Carbon steel nickel plating	22	Screw	Carbon steel nickel plating
10	Retaining ring	Carbon steel nickel plating	23	O-ring	Nitrile rubber NBR
11	Oilless bearing	Oil-impregnated sintered alloy	24	Stroke pad	Hard anodised aluminium alloy
12	Rod packing	Nitrile rubber NBR	25	Dust cover	Carbon steel - NBR
13	Piston packing	Nitrile rubber NBR			

Guiding and stopper cylinders

Bores from 12 to 63 mm

Standard dimensions



Type: **GPB - GPS**

(Bores $\varnothing 12 \div \varnothing 25$)

XX View

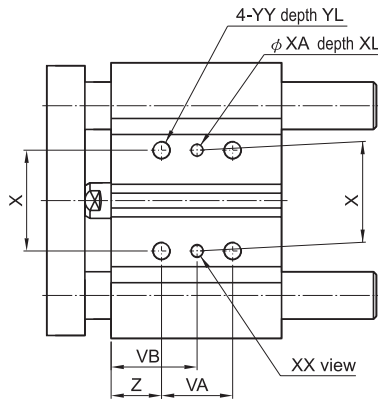
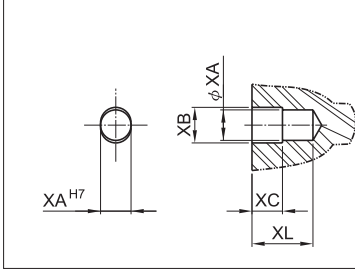

Groove dimensions

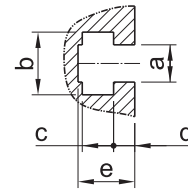

Bore	a	b	c	d	e
$\varnothing 12$	4,4	7,4	3,7	2	6,2
$\varnothing 16$	4,4	7,4	3,7	2,5	6,7
$\varnothing 20$	5,4	8,4	4,5	2,3	7,3
$\varnothing 25$	5,4	8,4	4,5	3	8,2

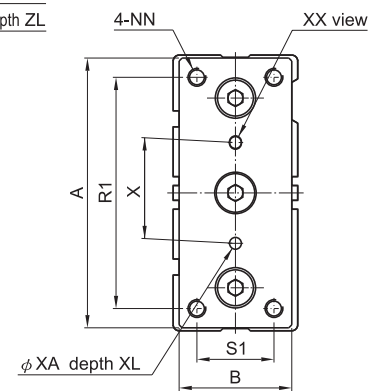
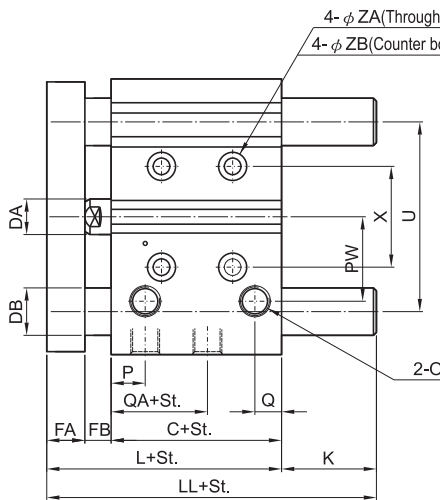
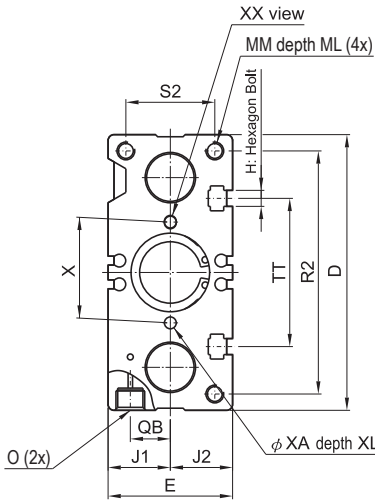

\varnothing mm	Stroke	A	B	C	D	DA	DB		E	FA	FB	H	J1	J2	L	MM	ML	NN	O	P	Q
							GPB	GPS													
12	10-100	56	22	29	58	6	8	6	26	8	5	M4	13	13	42	M4	10	M4	M5	11	7.5
		62	25	33	64	8	10	8	30	8	5	M4	15	15	46	M5	12	M5	M5	11	8
20	20-175	81	30	37	83	10	12	10	36	10	6	M5	18	18	53	M5	13	M5	1/8"	11.5	9
		91	38	37.5	93	12	16	12	42	10	6	M5	21	21	53.5	M6	15	M6	1/8"	11.5	9

\varnothing mm	Stroke	QA	QB	PW	TT	U	VA			VB			S1	S2	R1	R2	X ± 0.02	XA H7	XB	VC
							st. ≤ 30	30 < st. ≤ 100	st. > 100	st. ≤ 30	30 < st. ≤ 100	st. > 100								
12	10-100	12	7.5	18	37	41	20	40	-	15	25	-	14	18	48	50	23	3	3.5	3
		14	10	19	38	46	24	44	-	17	27	-	16	22	54	56	24	3	3.5	3
20	20-175	12.5	11.5	25	44	54	24	44	120	29	39	77	18	24	70	72	28	3	3.5	3
		12.5	13.5	28.5	50	64	24	44	120	29	39	77	28	30	78	82	34	4	4.5	3

\varnothing mm	Stroke	XL	YY	YL	Z	ZA	ZB	ZL	GPB				GPS							
									K		LL		K			LL				
									st. ≤ 50	st. > 50	st. ≤ 50	st. > 50	st. ≤ 30	30 < st. ≤ 100	st. > 100	st. ≤ 30	30 < st. ≤ 100	st. > 100		
12	10-100	6	M5	10	5	4.3	8	4.5	0	15	42	57	0	15	-	42	57	-	-	-
		6	M5	10	5	4.3	8	4.5	0	22	46	68	0	22	-	46	68	-	-	-
20	20-175	6	M6	12	17	5.6	9.5	5	0	28	53	81	0	28	52	53	81	105	-	-
		6	M6	12	17	5.6	9.5	5.5	0	29	53.5	82.5	0	31	50	53.5	84.5	103.5	-	-

Type: **GPB - GPS**
(Bores $\varnothing 32 \div \varnothing 63$)

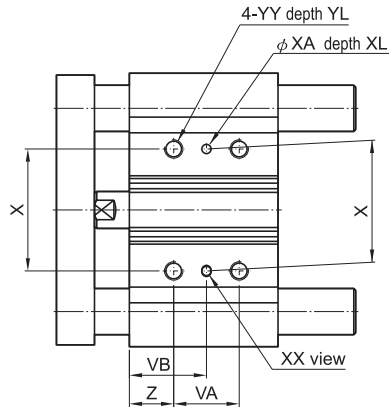
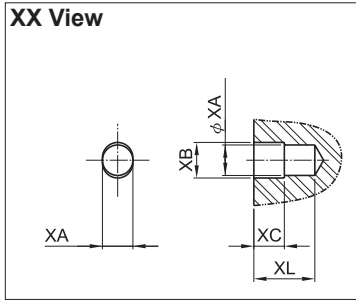

Groove dimensions

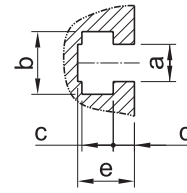

Bore	a	b	c	d	e
$\varnothing 32$	6.5	10.5	5.35	3.5	9.5
$\varnothing 40$	6.5	10.5	5.35	4	11
$\varnothing 50$	8.5	13.5	7.5	4.5	13.5
$\varnothing 63$	11	17.8	10	7	18.5

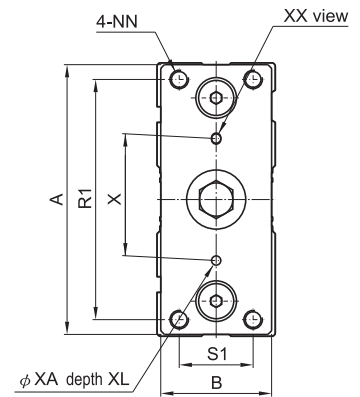
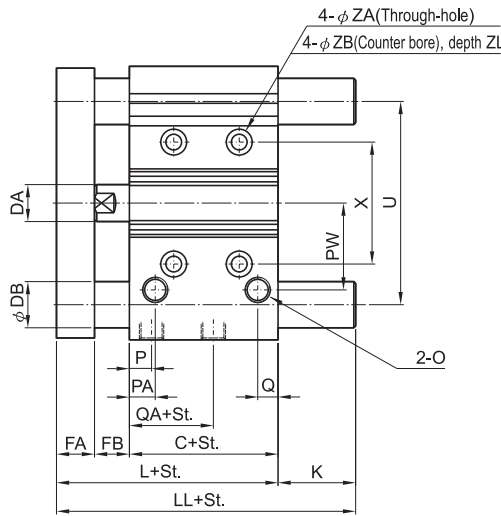
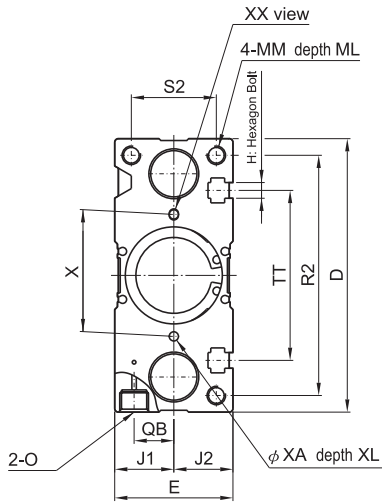

\varnothing mm	Stroke	A	B	C	D	DA	DB		E	FA	FB	H	J1	J2	L	MM	ML	NN	O	P	Q
							GPB	GPS													
32	25, 50, 75, 100, 125, 150	110	44	37.5	112	16	20	16	48	12	10	M6	24	24	59.5	M8	20	M8	1/8"	11.5	10
40		118	44	44	120	16	20	16	54	12	10	M6	27	27	66	M8	20	M8	1/8"	14	11
50		146	60	44	148	20	25	20	64	16	12	M8	32	32	72	M10	22	M10	1/4"	12	11
63		158	70	49	162	20	25	20	78	16	12	M10	39	39	77	M10	22	M10	1/4"	16.5	13

\varnothing mm	Stroke	QA	QB	PA	PW	TT	U	VA			VB			S1	S2	R1	R2	X ± 0.02	XA H7	XB
								25	50-100	st. > 100	25	50-100	st. > 100							
32	25, 50, 75, 100, 125, 150	5	16.5	11.5	34	63	78	24	48	124	33	45	83	30	34	96	98	42	4	4.5
40		11	18	14	38	72	86	24	48	124	34	46	84	30	40	104	106	50	4	4.5
50		9	21.5	14	47	92	110	24	48	124	36	48	86	40	46	130	130	66	5	6
63		14	28	16.5	55	110	124	28	52	128	38	50	88	50	58	130	142	80	5	6

\varnothing mm	Stroke	XC	XL	YY	YL	Z	ZA	ZB	ZL	GPB				GPS					
										K		LL		K		LL			
										25, 50	st. > 50	25, 50	st. > 50	25, 50	75, 100	st. > 100	25, 50	75, 100	st. > 100
32	25, 50, 75, 100, 125, 150	3	6	M8	16	21	6.5	11	7.5	8	45	67.5	104.5	8	45	65	67.5	104.5	124.5
40		3	6	M8	16	22	6.5	11	7.5	1.5	38.5	67.5	104.5	1.5	38.5	58.5	67.5	104.5	124.5
50		4	8	M10	20	24	8.5	14	9	6.5	48.5	78.5	120.5	6.5	48.5	68.5	78.5	120.5	140.5
63		4	8	M10	20	24	8.5	14	9	1.5	43.5	78.5	120.5	1.5	43.5	63.5	78.5	120.5	140.5