

Compact Cylinders ISO 21287

Bores from 16 to 125 mm



Standard executions		
Version	Symbol	Type
Single acting magnetic with female thread		CIS
Double acting magnetic with female thread		CI
Double acting magnetic anti-rotating (from 16 to 100)		CISN
Double acting magnetic anti-rotating (from 16 to 100)		CIN



For the magnetic reed switches type ASV see from page 1.110.1
 For mounting accessories see from page 1.97.1
 For rod mountings see from page 1.85.1



On request, they can be supplied according to 2014/34/EU - ATEX

Series of compact cylinders conforming to ISO 21287 standards. The new barrel with grooves allow the mounting of the magnetic reed switches directly in the tube without brackets; the reed switch will not protrude out the barrel profile. This series is equipped with elastic dampers on the piston. Only magnetic version available. One or more magnetic reed switches can be mounted.

Options	Suffix
Single acting, rear spring (page 1.16.5)	T
Male thread on piston-rod (page 1.16.5)	M
Through-rod (page 1.16.5)	P
Rod in stainless steel AISI 304 (only for Ø 32 - 40 - 50 - 63 - 80 - 100 - 125)	K
Seals FKM -20°C ÷ +150°C	V
Scraper ring only FKM -20°C ÷ +80°C	V1
Low temperature seals -40°C ÷ +80°C	BT
Tandem with coupled rods (page 1.16.6)	TA1
Tandem with independent rods (page 1.16.6)	TA2
Tandem back to back (page 1.16.6)	TA3
Tandem front to front (page 1.16.6)	TA4
Extended rod (indicate the requested WH dimension in mm. E.g.: WH-50)	WH-...
Special male thread (indicate the requested thread. E.g. : R-M 10x1,5). The dimension AM of the special thread will be the same as the standard. The cylinder will be supplied without rod nut.	R-M...
Special on request	/S

When possible options can be combined. The suffix of the options are to be added to the model number of the standard product, as shown in the following table. How to order: 63/100CIMP

63	/	100	CI	M	P
Bore	/	Stroke	Type	Option	Option

Seal kits	
n. 1	Rod seal
n. 2	Tube O-ring
n. 1	Piston lip-seal

How to order: 32 / SG / CIP

32	/	SG	/	CI	P
Bore	/	Seal kit	/	Type	Option

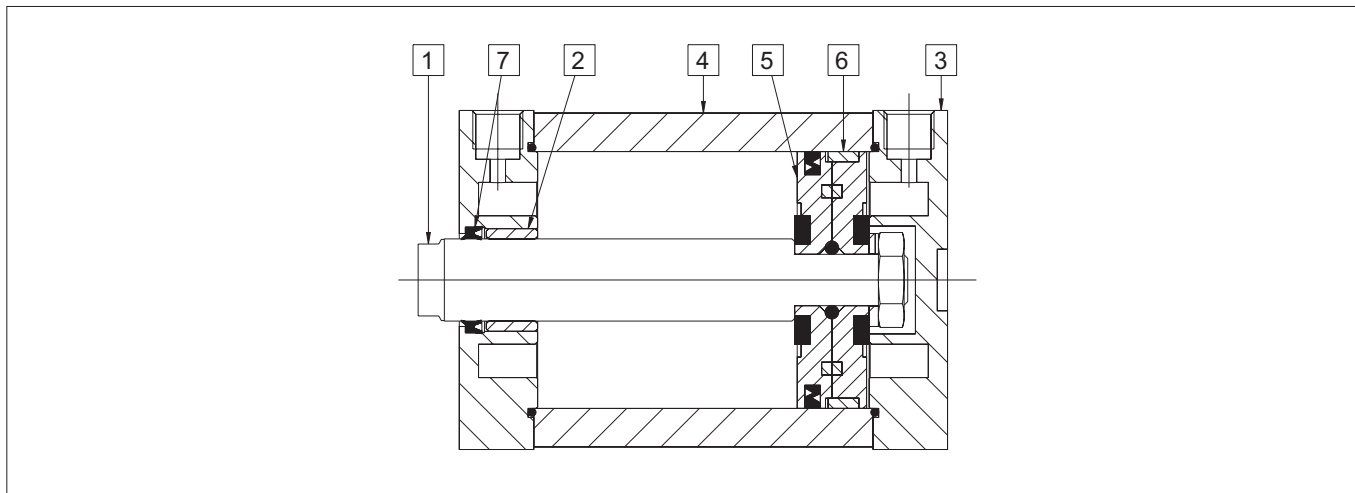

Materials (standard types)	
1 Rod	Stainless steel AISI 304 (Ø 16 - 25) Chrome-plated steel C45 (Ø 32 - 125)
2 Bushing	Stainless steel, sintered bronze, PTFE
3 Heads	Anodised aluminium
4 Tube	Anodised aluminium
5 Piston	PTFE (Ø 16) Aluminium (Ø 25 - 125)
6 Guide ring	PTFE
7 Rod seals	Polyurethane
Other seals	Nitrilic rubber NBR

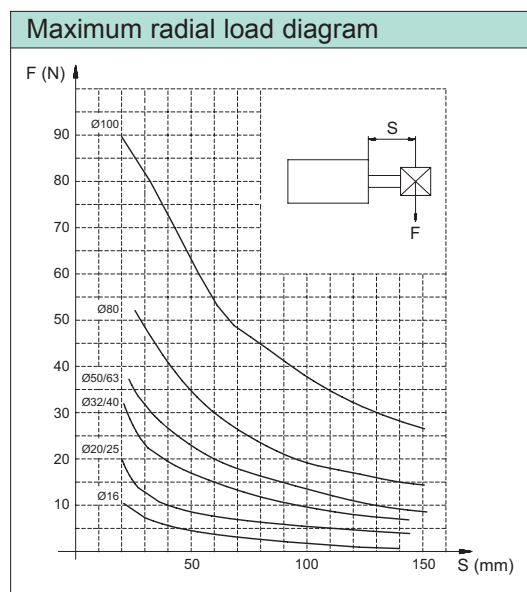

Technical data	
Fluid	Compressed filtered air with or without lubrication. Lubrication, if started, must be continued.
Pressure	Single acting 2 ÷ 10 bar - Double acting 1 ÷ 10 bar
Temperature	-20 °C ÷ +80 °C

Bore (mm)	Standard strokes CIS	Standard strokes CI	Standard strokes CIN
16	5, 10, 15, 20, 25 (5÷25)	5, 10, 15, 20, 25, 30, 40, 50 (5÷300)	5, 10, 15, 20, 25, 30, 40, 50 (5÷200)
20	5, 10, 15, 20, 25 (5÷25)	5, 10, 15, 20, 25, 30, 40, 50, 60 (5÷300)	5, 10, 15, 20, 25, 30, 40, 50, 60 (5÷200)
25	5, 10, 15, 20, 25 (5÷25)	5, 10, 15, 20, 25, 30, 40, 50, 60 (5÷300)	5, 10, 15, 20, 25, 30, 40, 50, 60 (5÷200)
32	5, 10, 15, 20, 25 (5÷25)	5, 10, 15, 20, 25, 30, 40, 50, 60, 80 (5÷400)	5, 10, 15, 20, 25, 30, 40, 50, 60, 80 (5÷300)
40	5, 10, 15, 20, 25 (5÷25)	5, 10, 15, 20, 25, 30, 40, 50, 60, 80 (5÷400)	5, 10, 15, 20, 25, 30, 40, 50, 60, 80 (5÷300)
50	5, 10, 15, 20, 25 (5÷25)	5, 10, 15, 20, 25, 30, 40, 50, 60, 80 (5÷400)	5, 10, 15, 20, 25, 30, 40, 50, 60, 80 (5÷300)
63	5, 10, 15, 20, 25 (5÷25)	5, 10, 15, 20, 25, 30, 40, 50, 60, 80 (5÷400)	5, 10, 15, 20, 25, 30, 40, 50, 60, 80 (5÷300)
80	15, 20, 25 (15÷25)	15, 20, 25, 30, 40, 50, 60, 80 (15÷500)	15, 20, 25, 30, 40, 50, 60, 80 (15÷400)
100	15, 20, 25 (15÷25)	15, 20, 25, 30, 40, 50, 60, 80, 100 (15÷500)	15, 20, 25, 30, 40, 50, 60, 80, 100 (15÷400)
125	15, 20, 25 (15÷25)	15, 20, 25, 30, 40, 50, 60, 80, 100 (15÷500)	15, 20, 25, 30, 40, 50, 60, 80, 100 (15÷400)

Type: **CI - CIS**
Bore: 16 - 20 - 25

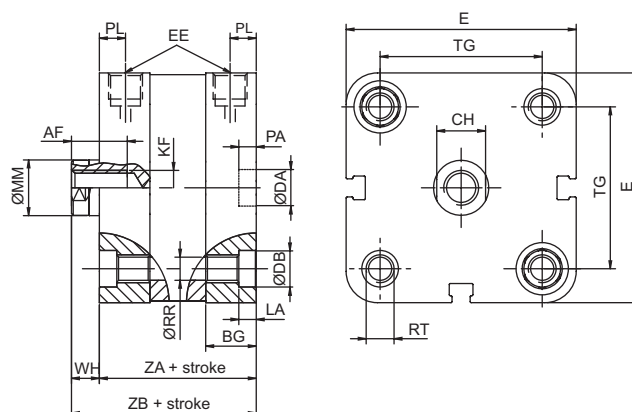

Ø (mm)	Ø MM f7	AF	WH	ZA	ZB	KF	EE	BG	RR	TG	E	RT	LA	Ø DB	PL	CH	Ø DA H9	PA +0.1
16	8	10	4,5	35	39,5	M4	M5	12,7	3,1	18	29	M4	3,5	6	8	7	9	2,1
20	10	10	6	37	43	M6	M5	15	4,1	22	36	M5	4,1	7,5	6	8	9	2,1
25	10	10	6	39	45	M6	M5	15	4,1	26	40	M5	4,1	7,5	5	8	9	2,1

Type: **CI - CIS**
Bore: 32 - 40 - 50 - 63

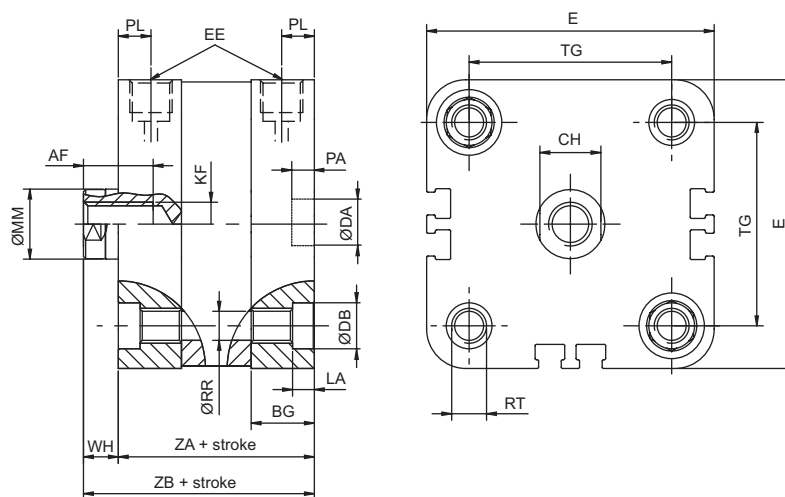

Ø (mm)	Ø MM f7	AF	WH	ZA	ZB	KF	EE	BG	RR	TG	E	RT	LA	Ø DB	PL	CH	Ø DA H9	PA +0.1
32	12	12	7	44	51	M8	1/8"	16	5,1	32,5	47,5	M6	5,1	8,5	7	10	9	2,1
40	12	12	7	45	52	M8	1/8"	16	5,1	38	55	M6	5,1	8,5	7,5	10	9	2,1
50	16	16	8	45	53	M10	1/8"	16	6,4	46,5	66	M8	6,1	10,5	7,5	14	12	2,6
63	16	16	8	49	57	M10	1/8"	16	6,4	56,5	78	M8	6,1	10,5	7	14	12	2,6



Compact Cylinders ISO 21287

Bores from 16 to 125 mm

Standard dimensions

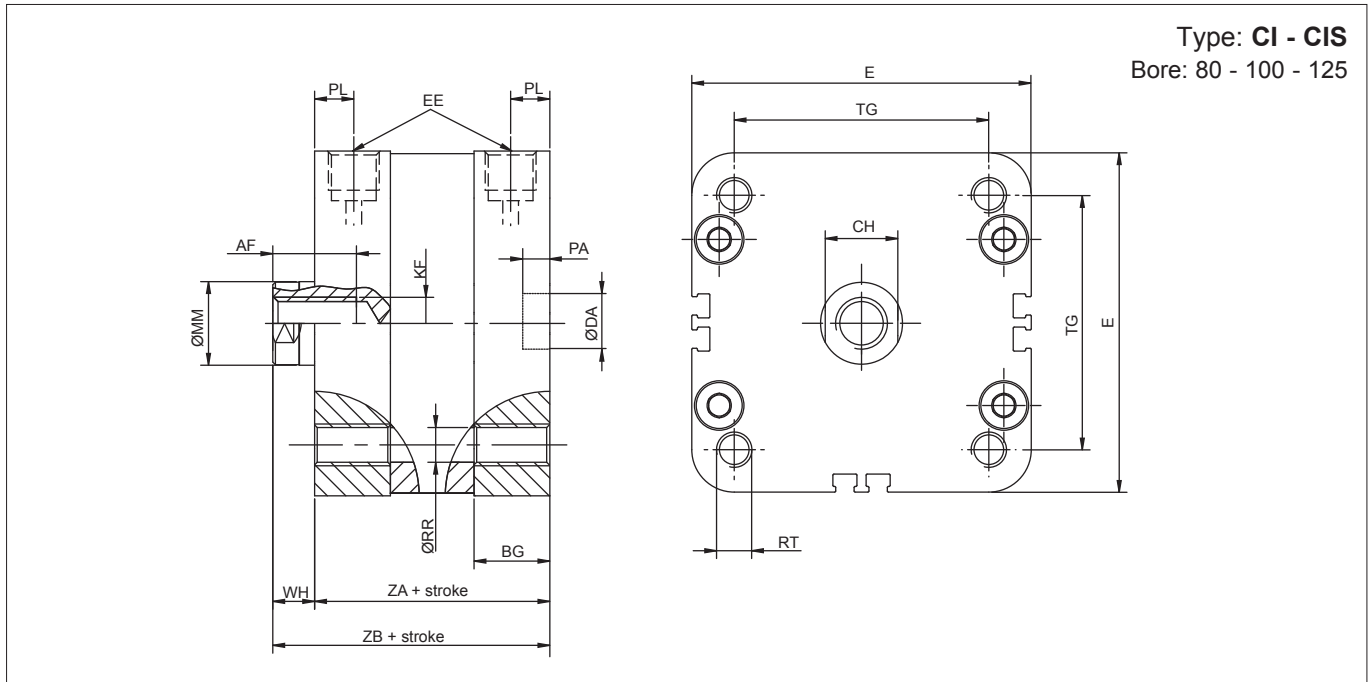

Ø (mm)	Ø MM f7	AF	WH	ZA	ZB	KF	EE	BG	RR	TG	E	RT	PL	CH	Ø DA H9	PA +0.1
80	20	20	10	54	64	M12	1/8"	17	8,4	72	96	M10	8	17	12	2,6
100	20	20	10	67	77	M12	1/8"	17	8,4	89	116	M10	8,5	17	12	2,6
125	25	24	11	81	92	M16	1/4"	20	10,2	110	135	M12	10	21	12	2,6

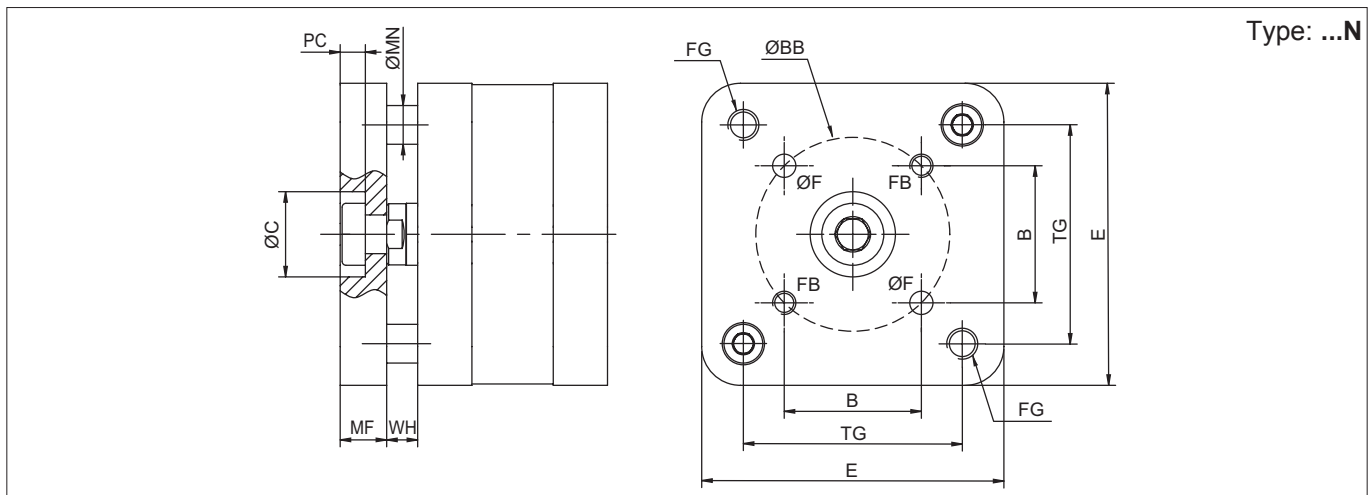

Ø (mm)	WH	MF +0,1	E	TG	B	FG	ØBB ±0,1	ØF +0,1	FB	ØC H9	PC	MN f7
16	4,5	6	29	18	9.9	M4	14	3	M3	7,5	4,5	6
20	6	8	36	22	12	M5	17	4	M4	10,5	4,5	6
25	6	8	40	26	15.6	M5	22	5	M5	14	4,5	6
32	7	10	47,5	32,5	19.8	M6	28	5	M5	17	5,5	8
40	7	10	55	38	23,3	M6	33	5	M5	17	5,5	8
50	8	12	66	46,5	29.7	M8	42	6	M6	22	6,5	10
63	8	12	78	56,5	35,4	M8	50	6	M6	22	6,5	10
80	10	14	96	72	46	M10	65	8	M8	24	7,5	10
100	10	14	116	89	56.6	M10	80	10	M10	24	7,5	12

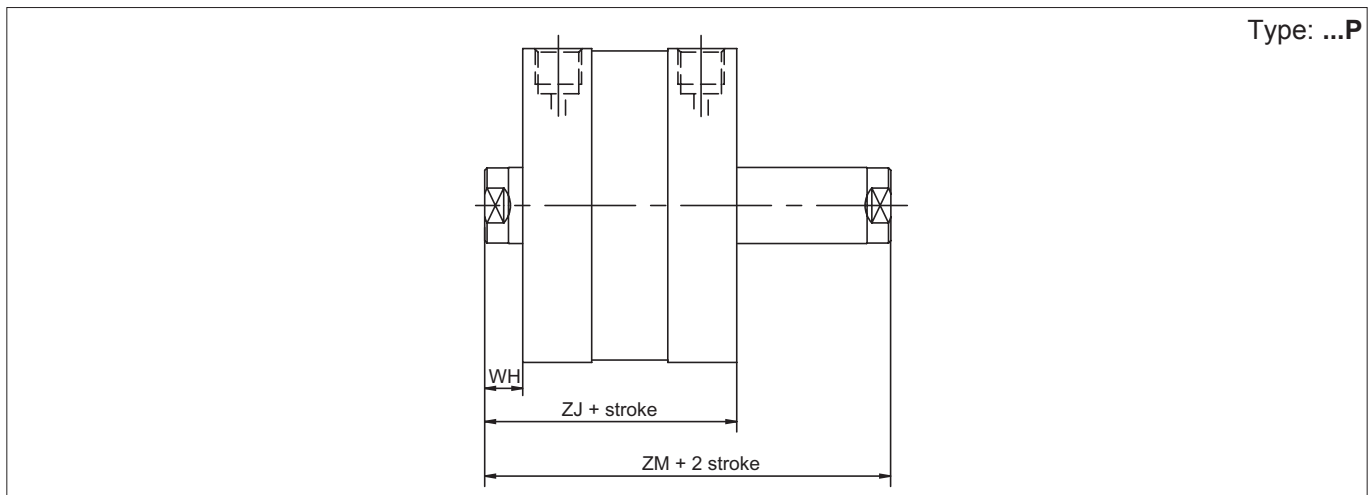
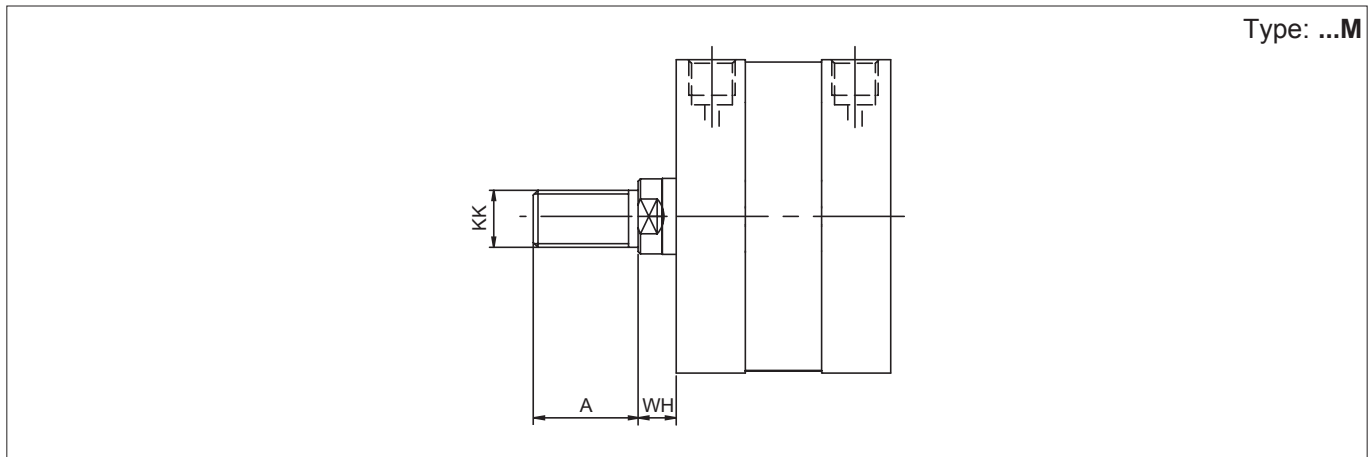
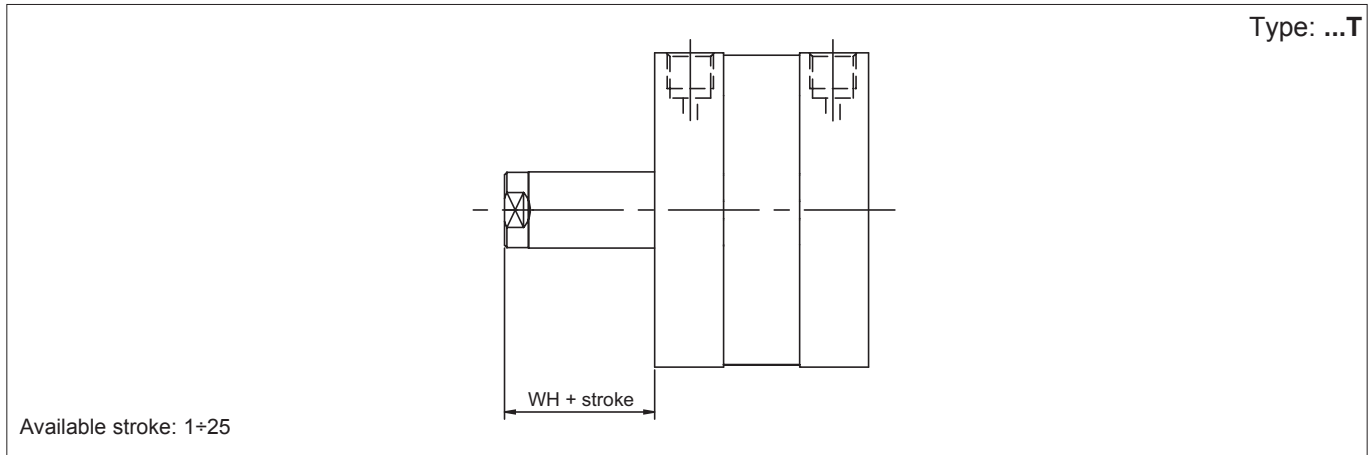

Ø (mm)	A	KK	WH	ZJ	ZM
16	12	M6	4,5	-	-
20	16	M8x1,25	6	43	49
25	16	M8x1,25	6	45	51
32	19	M10x1,25	7	51	58
40	19	M10x1,25	7	52	59
50	22	M12x1,25	8	53	61
63	22	M12x1,25	8	57	65
80	28	M16x1,5	10	64	74
100	28	M16x1,5	10	77	87
125	40	M20x1,5	11	92	103

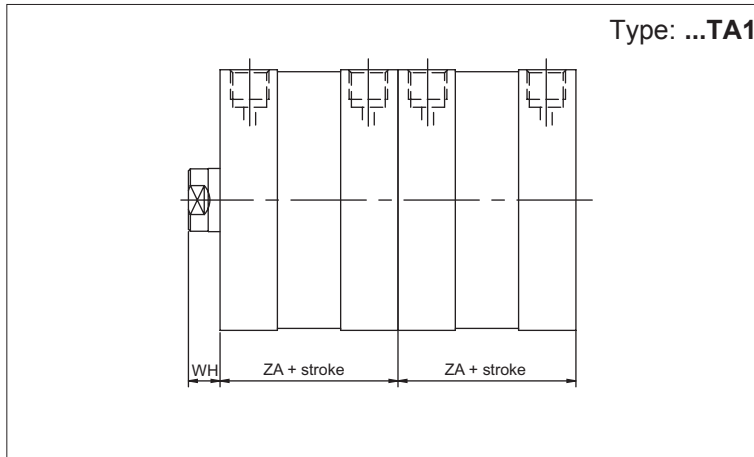

∅ (mm)	ZA	WH
25	39	6
40	45	7
63	49	8

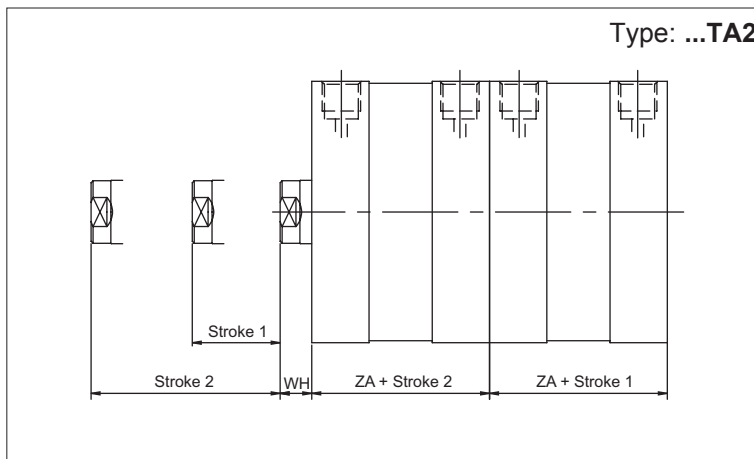

∅ (mm)	ZA	WH
25	39	6
40	45	7
63	49	8

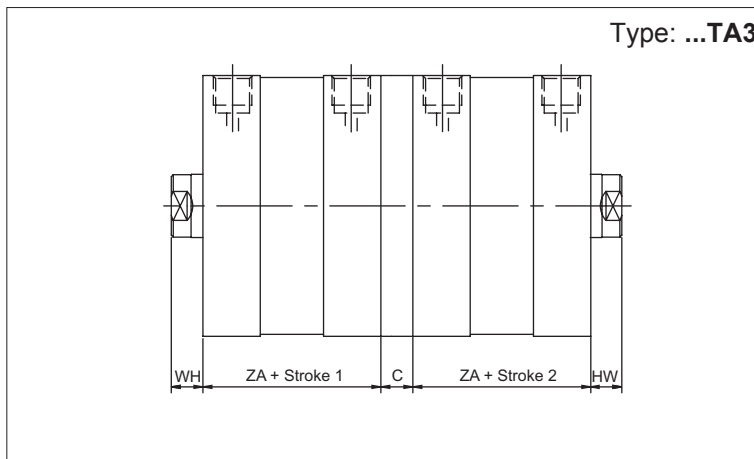

∅ (mm)	ZA	WH	C
20	37	6	13
25	39	6	13
32	44	7	15
40	45	7	15
50	45	8	15
63	49	8	15
80	54	10	17
100	67	10	19,5
125	81	11	19,5

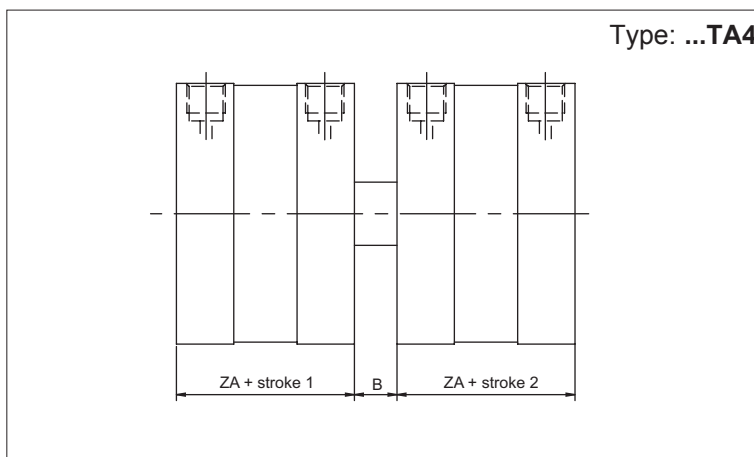

∅ (mm)	ZA	WH
20	37	9
25	39	11
32	44	12
40	45	13
50	45	15
63	49	15
80	54	16
100	67	20