

Standard executions		
Version	Symbol	Type
Non magnetic		MD
Magnetic		MDM
Magnetic with cushionings from bore 16 to 25 mm.		MDMA

II 2Gc IIC T5
II 2Dc T100°C

On request, they can be supplied according to 2014/34/EU - **ATEX**

Options		Suffix
Through rod	from bore 16 to 25 mm.	P
Seals FKM	-20°C ÷ +150°C	V
Extended rod in hardened and chrome plated steel suitable for static piston rod brake	from bore 12 to 25 mm.	B
Special versions on request		/ S

The options can be combined (when this is possible)



Series of cylinders conforming to ISO 6432 standards
The heads are connected with the body through rolling; this guarantees perfect tightening.

The cushionings are in nitrile rubber to relieve the impact of the piston; the MDMA type is provided with adjustable air cushioning at both ends.

The standard cylinders are provided with head and rod nut.
One or more magnetic reed switches can be applied to the magnetic type.

For the magnetic reed switches type ASV see from page 1.110.1

For mounting accessories see from page 1.95.1.

For rod accessories see from page 1.85.1.

For dimensions of the cylinder with the piston-rod brake see page 1.75.5.

How to order: 25 / 50 MDMP

25	/	50	MDM	P
Bore	/	Stroke	Type	Option

Technical data	
Fluid	Compressed filtered air with or without lubrication. Lubrication, if started, must be continued.
Pressure	max 10 bar
Temperature range	-30°C ÷ +80°C (standard) -20°C ÷ +150°C (V)
Materials	Heads: Anodised aluminium Tube: Stainless steel AISI 304 Rod: Stainless steel AISI 304 Seals: Polyurethane - Brass piston

Bore (mm)	Standard strokes (mm)	Max stroke (mm)	Stroke di decelerazione (mm)
8	10, 25, 50, 80 100, 125, 160 200, 250, 320, 400, 500	200	—
10		200	—
12		320	—
16		1000	16
20		1000	17
25		1000	20

The MDMA type can only be supplied with bores 16, 20, 25; the minimum stroke is 25 mm.

See page 1.1.3 to calculate the cylinder force.

Seal kits not available for these cylinders.

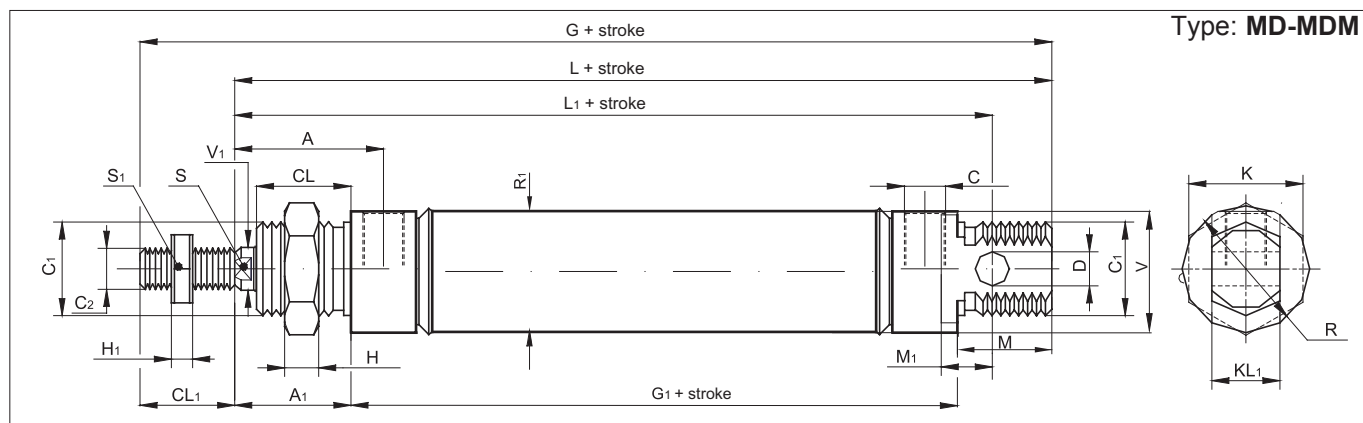

Ø mm	C ₂	V ₁	C ₁	R	KL ₁	R ₁	V	D	CL ₁	L ₁	L	M	G ₁	A ₁	CL	A	M ₁	S	C	G	K	H	H ₁	S ₁
8	M4	4	M12x1,25	16	8	9,27	15	4	12	64	74	12	46	16	12	21	6	/	M5	86	19	7	3	7
10	M4	4	M12x1,25	16	8	11,27	15	4	12	64	74	12	46	16	12	21	6	/	M5	86	19	7	3	7
12	M6	6	M16x1,5	21	12	13,27	19	6	16	75	89	16	51	22	16	27	9	5	M5	105	19	8	3,5	12
16	M6	6	M16x1,5	21	12	17,27	19	6	16	82	96	16	58	22	16	27	9	5	M5	112	19	8	3,5	12
20	M8	8	M22x1,5	30	16	21,27	28,5	8	20	95	105	22	59	24	18	31,5	12	7	1/8"	125	27	6	5	14
25	M10x1,25	10	M22x1,5	30	16	26,5	28,5	8	22	104	114	22	64	28	20	36	12	9	1/8"	136	27	6	6	17

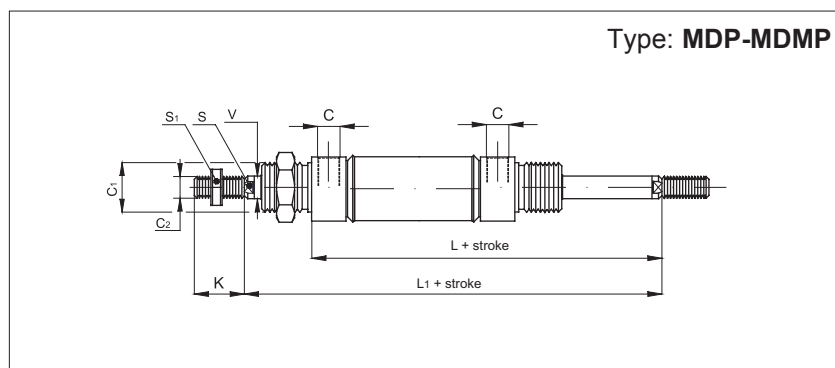
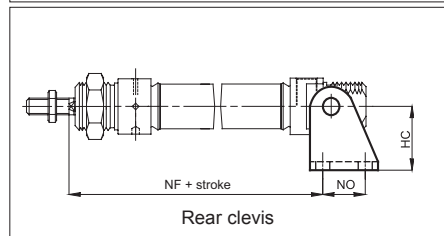
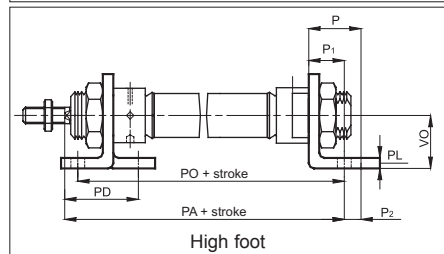
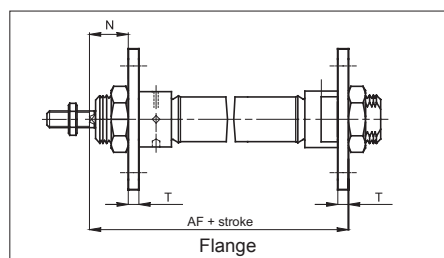

Ø mm	L	L ₁	C	C ₁	C ₂	S	S ₁	V	K
8	62	78	M5	M12x1,25	M4	/	7	4	12
10	62	78	M5	M12x1,25	M4	/	7	4	12
12	73	95	M5	M16x1,5	M6	5	12	6	16
16	80	102	M5	M16x1,5	M6	5	12	6	16
20	83	107	1/8"	M22x1,5	M8	7	14	8	20
25	92	120	1/8"	M22x1,5	M10x1,25	9	17	10	22

Ø mm	AF	HC	P	P ₁	P ₂	PA	PD	PL	PO	T	VO	N	NF	NO
8	65	24	16	11	5	73	24	3	68	3	16	13	62,5	12,5
10	65	24	16	11	5	73	24	3	68	3	16	13	62,5	12,5
12	77	27	20	14	6	87	32	4	79	4	20	18	73	15
16	84	27	20	14	6	94	32	4	86	4	20	18	80	15
20	88	30	25	17	8	100	36	5	93	5	25	19	91	20
25	97	30	25	17	8	109	40	5	98	5	25	23	100	20

For dimensions and codes of the accessories see page 1.95.1.

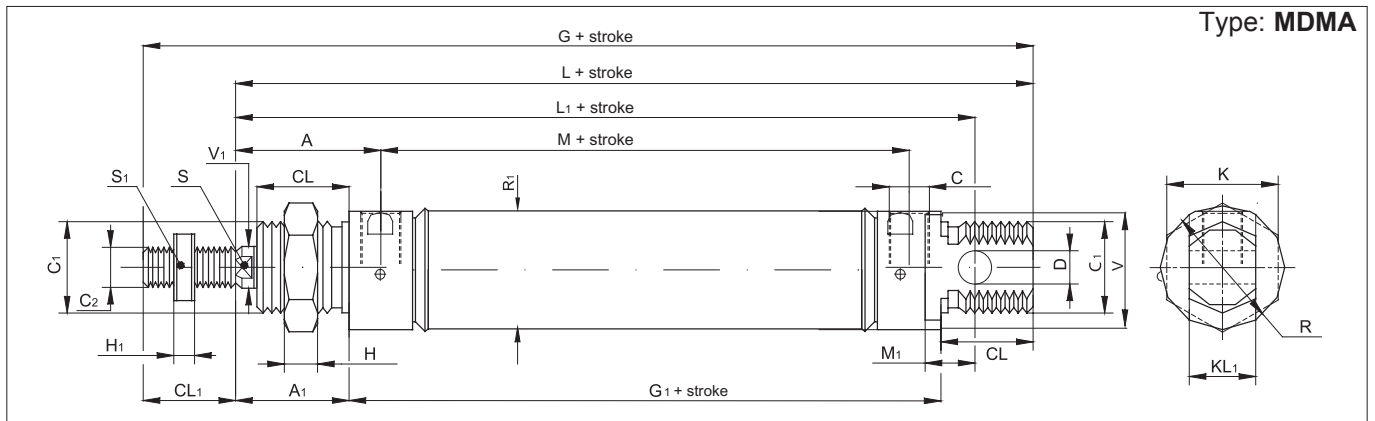

Ø mm	C ₂	V ₁	C ₁	R	KL ₁	R ₁	V	D	CL ₁	L ₁	L	M	G ₁	A ₁	CL	A	M ₁	S	C	G	K	H	H ₁	S ₁
16	M6	6	M16x1,5	21	12	17,27	18	6	16	82	93	18	53	22	18	27	9	5	M5	109	22	8	3,5	10
20	M8	8	M22x1,5	30	16	21,27	28,5	8	20	95	105	22	59	24	18	31,5	12	7	1/8"	125	27	6	5	14
25	M10x1,25	10	M22x1,5	30	16	26,5	28,5	8	22	104	114	22	64	28	20	36	12	9	1/8"	136	27	6	6	17

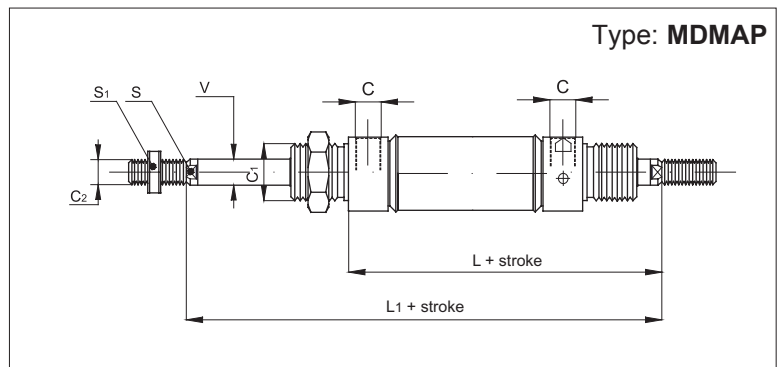
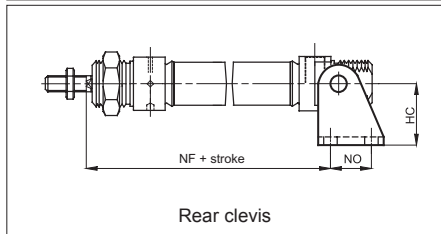
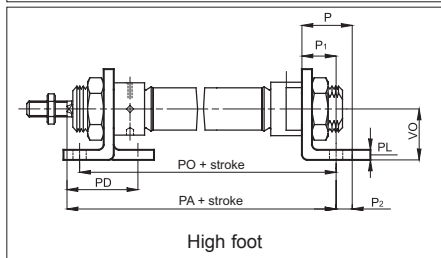
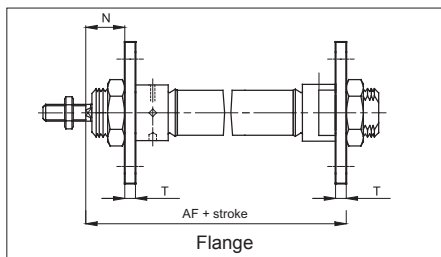

Ø mm	L	L ₁	C	C ₁	C ₂	S	S ₁	V
16	76	97	M5	M16x1,5	M6	5	10	6
20	83	107	1/8"	M22x1,5	M8	7	14	8
25	92	120	1/8"	M22x1,5	M10x1,25	9	17	10

Ø mm	AF	HC	P	P ₁	P ₂	PA	PD	PL	PO	T	VO	N	NF	NO
16	82	27	20	14	6	92	32	4	84	4	20	18	80	15
20	88	30	25	17	8	100	36	5	93	5	25	19	91	20
25	97	30	25	17	8	109	40	5	98	5	25	23	100	20

For dimensions and codes of the accessories see page 1.95.1.