



- Popis výrobku:** série lisovacích tvarovek z uhlíkové oceli s M-profilem v rozměrech 12 až 108 mm
- Aplikace:** určené pro rozvody stlačeného vzduchu, topné rozvody, klimatizace, vedení vakua a solární aplikace
- Pracovní tlak:** 16 bar
- Max. prac. teplota:** 120 °C
- Síla stěny:** 1,5 mm u tvarovek 12 - 54 mm  
2 mm u tvarovek 76 - 108 mm
- Materiál:** nelegovaná ocel E 195 (Rst 34-2) dle ČSN EN 10305-3, uvnitř i vně galvanicky pozinkované, těsnění - EPDM černé (DVGW W 270)



### Příruby se spojkou

Obj. č.	d (mm)	d1 (mm)	L (mm)	Z (mm)	Z1 (mm)	D (mm)	D1 (mm)	Hmotnost (g)	Balení (ks)
MC1F-06567	66	18	83	50	18	185	145	2 891	1
MC1F-06576	76	18	88	55	18	185	145	3 325	1
MC1F-08089	88	18	99	63	20	200	160	4 139	1
MC1F-100108	108	18	111	76	20	220	180	5 035	1

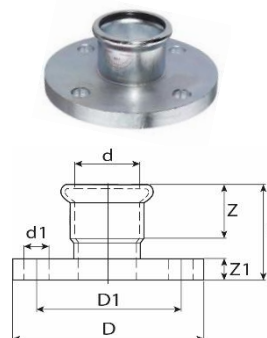

### Přímé spojky

Obj. č.	d (mm)	L (mm)	Z (mm)	Hmotnost (g)	Balení (ks)
MC1-12	12	47	13	25	10
MC1-15	15	53	13	34	10
MC1-18	18	53	13	42	10
MC1-22	22	55	13	50	10
MC1-28	28	59	13	68	10
MC1-35	35	65	13	91	4
MC1-42	42	76	16	127	2
MC1-54	54	86	17	197	2
MC1-67	66,7	130	30	500	1
MC1-76	76,1	140	30	600	1
MC1-89	88,9	164	38	1 200	1
MC1-108	108	195	43	1 800	1

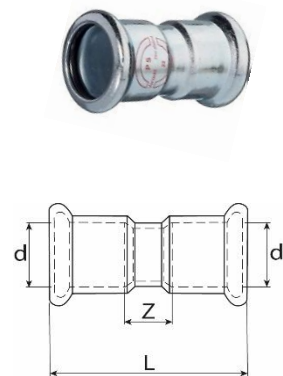

### Přímé spojky bez zarážky

Obj. č.	d (mm)	L (mm)	Hmotnost (g)	Balení (ks)
MC1S-15	15	80	55	10
MC1S-18	18	80	63	10
MC1S-22	22	84	81	10
MC1S-28	28	91	107	10
MC1S-35	35	102	146	10
MC1S-42	42	120	210	4
MC1S-54	54	140	306	4
MC1S-67	66,7	200	405	1
MC1S-76	76,1	230	467	1
MC1S-89	88,9	260	1 328	1
MC1S-108	108	310	1 860	1

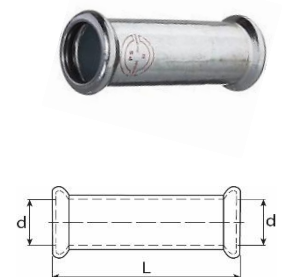



### Redukované přímé spojky

Obj. č.	d (mm)	d1 (mm)	L (mm)	Z (mm)	Hmotnost (g)	Balení (ks)
MC1R-1522	22	15	61,5	22	51	10
MC1R-1528	28	15	62	20	60	10
MC1R-2228	28	22	68	23	72	10
MC1R-2835	35	28	69,5	21	87	4



### Přímé spojky s vnitřním kuželovým závitem

Obj. č.	d (mm)	Rp	L (mm)	Z (mm)	Hmotnost (g)	Balení (ks)
MC2-3812	12	3/8"	40	7,5	30	10
MC2-1215	15	1/2"	41	8,5	51	10
MC2-1218	18	1/2"	40	7,5	57	10
MC2-3418	18	3/4"	40	7,5	77	10
MC2-1222	22	1/2"	43	9,5	123	10
MC2-3422	22	3/4"	43	8,5	93	10
MC2-1022	22	1"	50	10	144	10
MC2-1028	28	1"	50	8	130	10
MC2-1035	35	1"	54	9	175	4
MC2-5435	35	1 1/4"	56	9	182	4
MC2-1542	42	1 1/2"	76	21	232	4
MC2-2054	54	2"	87	22	356	2

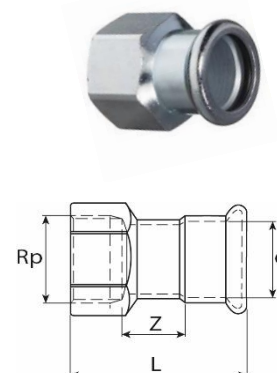

### Přímé spojky s vnějším kuželovým závitem

Obj. č.	d (mm)	R	L (mm)	Z (mm)	Hmotnost (g)	Balení (ks)
MC3-3812	12	3/8"	31	14	30	10
MC3-1212	12	1/2"	36	19	44	10
MC3-3815	15	3/8"	35	15	36	10
MC3-1215	15	1/2"	39	19	44	10
MC3-1218	18	1/2"	39	19	53	10
MC3-3418	18	3/4"	40	20	65	10
MC3-1222	22	1"	44	23	75	10
MC3-3422	22	3/4"	44	23	81	10
MC3-1022	22	1"	44	23	120	10
MC3-3428	28	3/4"	43	20	99	10
MC3-1028	28	1"	44	21	102	10
MC3-1035	35	1"	49	24	148	4
MC3-5435	35	1 1/2"	55	29,5	170	4
MC3-1542	42	1 1/2"	78	48	232	4
MC3-2054	54	2"	90,5	55,5	356	2
MC3-2567	66,7	2 1/2"	93	43	700	1
MC3-2576	76,1	2 1/2"	95	40	808	1
MC3-3089	88,9	3"	107	44	1 171	1

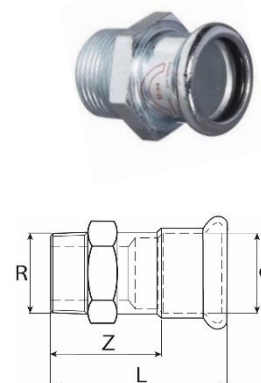

### Přechodky s vnitřním kuželovým závitem

Obj. č.	d (mm)	Rp	L (mm)	Z (mm)	Hmotnost (g)	Balení (ks)
MC7-1215	15	1/2"	53	32	54	10
MC7-1218	18	1/2"	60	35	61	10
MC7-1222	22	1/2"	59	38	102	10
MC7-3422	22	3/4"	60	38	107	10

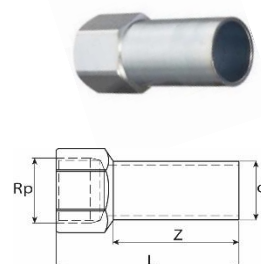



### Přechodky s vnějším kuželovým závitem

Obj. č.	d (mm)	R	L (mm)	Z (mm)	Hmotnost (g)	Balení (ks)
MC8-1215	15	1/2"	57	32	67	10
MC8-1218	18	1/2"	58	35	72	10
MC8-3422	22	3/4"	65	40	110	10

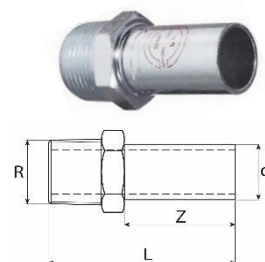

### Redukce

Obj. č.	d (mm)	d1 (mm)	L (mm)	Z (mm)	Hmotnost (g)	Balení (ks)
MC6-1215	15	12	50	13	31	10
MC6-1518	18	15	53	13	44	10
MC6-1522	22	15	63	43	37	10
MC6-1822	22	18	62	15	54	10
MC6-1528	28	15	69	22	67	10
MC6-1828	28	18	71	24	69	10
MC6-2228	28	22	72	51	75	10
MC6-2235	35	22	79	58	99	10
MC6-2835	35	28	78	55	111	4
MC6-2242	42	22	92	71	140	4
MC6-2842	42	28	89	66	140	4
MC6-3542	42	35	86	60	155	4
MC6-2254	54	22	112	91	194	2
MC6-2854	54	28	106	83	199	2
MC6-3554	54	35	104	78	223	2
MC6-4254	54	42	102	72	248	2
MC6-4267	66,7	42	114	34	398	1
MC6-5467	66,7	54	116	24	438	1
MC6-4276	76,1	42	129	44	434	1
MC6-5476	76,1	54	128	33	474	1
MC6-6776	76,1	66,7	128	23	528	1
MC6-5489	88,9	54	144	46	591	1
MC6-7689	88,9	76,1	145	27	660	1
MC6-67108	108	66,7	191	65	917	1
MC6-76108	108	76,1	184,5	53,5	971	1
MC6-89108	108	88,9	177,5	38,5	1 025	1

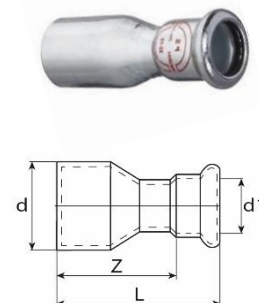

### Oblouky 90°

Obj. č.	d (mm)	L (mm)	Z (mm)	Hmotnost (g)	Balení (ks)
MC12-12	12	34,5	17,5	35	10
MC12-15	15	39	19,3	44	10
MC12-18	18	46	26	54	10
MC12-22	22	48	27	71	10
MC12-28	28	57	34	96	10
MC12-35	35	76	50,4	175	4
MC12-42	42	80	50	256	2
MC12-54	54	100	65,4	340	2
MC12-67	66,7	135	50	868	1
MC12-76	76,1	150	95	1 000	1
MC12-89	88,9	173	110	1 400	1
MC12-108	108	215	139	2 000	1

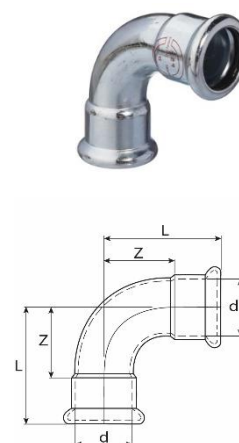



### Oblouky 90° se vsuvným koncem

Obj. č.	d (mm)	L (mm)	L1 (mm)	Z (mm)	Hmotnost (g)	Balení (ks)
MC12S-12	12	34,5	39	17,5	35	10
MC12S-15	15	39,3	45	19,3	52	10
MC12S-18	18	46	50	26	66	10
MC12S-22	22	48	54	27	92	10
MC12S-28	28	47	68	34	126	10
MC12S-35	35	76	79	50,4	171	4
MC12S-42	42	80	87	50	245	2
MC12S-54	54	100	107	65,4	370	2
MC12S-67	66,7	135	150	85	868	1
MC12S-76	76,1	150	158	95	1 000	1
MC12S-89	88,9	173	191	110	1 400	1
MC12S-108	108	215	238	139	2 000	1

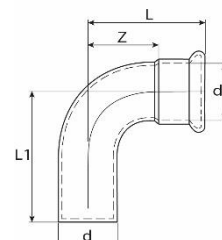

### Oblouky 90° s vnějším kuželovým závitem

Obj. č.	d (mm)	R	L (mm)	L1 (mm)	Z (mm)	Hmotnost (g)	Balení (ks)
MC13-3812	12	3/8"	34,5	41	17,5	60	10
MC13-1215	15	1/2"	41	48	21	72	10
MC13-1218	18	1/2"	56	52	26	89	10
MC13-3422	22	3/4"	48	60	27	118	10
MC13-1028	28	1"	57	67	34	185	4
MC13-5435	35	1 1/4"	76	88	50,4	309	4
MC13-1542	42	1 1/2"	80	87,6	50	367	2
MC13-2054	54	2"	100	105,5	65	587	1

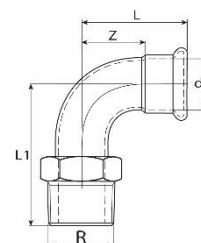

### Kolena 90° s vnějším kuželovým závitem

Obj. č.	d (mm)	R	L1 (mm)	L2 (mm)	Z (mm)	Hmotnost (g)	Balení (ks)
MC13K-3812	12	3/8"	49	35,5	23,5	88	10
MC13K-3815	15	3/8"	50	35,5	23,5	88	10
MC13K-1215	15	1/2"	54	41,5	28	88	10
MC13K-1218	18	1/2"	56	41,5	28	98	10
MC13K-3422	22	3/4"	63	49,5	32	123	10

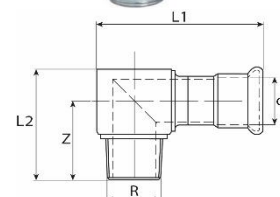

### Oblouky 90° s vnitřním kuželovým závitem

Obj. č.	d (mm)	L (mm)	L1 (mm)	Z (mm)	Z1 (mm)	Rp	Hmotnost (g)	Balení (ks)
MC14-1215	15	41	44	21	28,5	1/2"	71	10
MC14-1218	18	46	53	26	34,7	1/2"	98	10
MC14-3422	22	48	55,5	27	39	3/4"	142	10
MC14-1028	28	57	67	34	44	1"	226	4
MC14-5435	35	76	86	50,4	61	1 1/4"	309	4

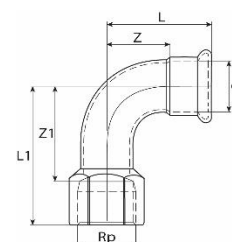



### Oblouky 90° se vsuvnými konci

Obj. č.	d (mm)	R (mm)	L (mm)	L1 (mm)	Hmotnost (g)	Balení (ks)
MC19-15	15	15,5	120	70	88	10
MC19-18	18	18	120	70	109	10
MC19-22	22	22	120	70	133	10
MC19-28	28	24	120	80	176	4
MC19-35	35	22	200	120	364	2
MC19-42	42	26,5	250	150	552	1
MC19-54	54	35	300	200	952	1

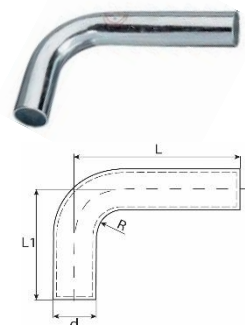

### Oblouky 45°

Obj. č.	d (mm)	L (mm)	Z (mm)	Hmotnost (g)	Balení (ks)
MC21-12	12	30	13	34	10
MC21-15	15	36	16	44	10
MC21-18	18	37	17	54	10
MC21-22	22	42	21	71	10
MC21-28	28	43	20	96	10
MC21-35	35	56	30,4	142	4
MC21-42	42	62	32	195	2
MC21-54	54	62	27,4	260	2
MC21-67	66,7	85	35	695	1
MC21-76	76,1	102	47	800	1
MC21-89	88,9	117	54	1 200	1
MC21-108	108	139	63	1 800	1



### Oblouky 45° se vsuvným koncem

Obj. č.	d (mm)	L (mm)	L1 (mm)	Z (mm)	Hmotnost (g)	Balení (ks)
MC21S-12	12	30	40	17	34	10
MC21S-15	15	36	42	16	44	10
MC21S-18	18	37	46	17	40	10
MC21S-22	22	42	52	21	75	10
MC21S-28	28	43	49	20	96	10
MC21S-35	35	56	62	30,4	142	4
MC21S-42	42	62	69	32	195	2
MC21S-54	54	62	69	27,4	260	2
MC21S-67	66,7	85	85	35	695	1
MC21S-76	76,1	102	110	47	800	1
MC21S-89	88,9	117	128	54	1 200	1
MC21S-108	108	139	160	63	1 800	1

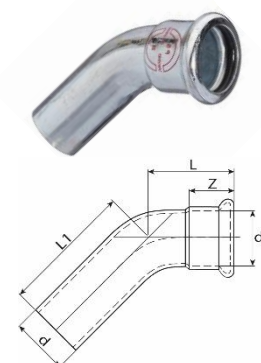

### Přemostňovací oblouky se vsuvnými konci

Obj. č.	d (mm)	R	L (mm)	Z (mm)	h (mm)	$\alpha$	$\beta$	Hmotnost (g)	Balení (ks)
MC22S-12	12	8	130	90	42	120°	30°	60	10
MC22S-15	15	10	129	97	44	126°	27°	75	10
MC22S-18	18	13	170,5	123	56	123°	29°	101	10
MC22S-22	22	9	163,5	118	53	129°	26°	132	10
MC22S-28	28	16	204,5	144	64	130°	25°	201	4

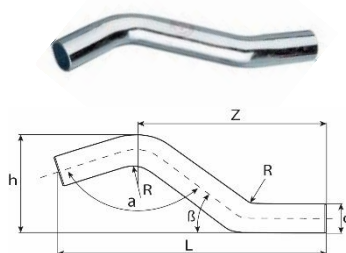



### T-spojky

Obj. č.	d (mm)	L (mm)	L1 (mm)	Z (mm)	Z1 (mm)	Hmotnost (g)	Balení (ks)
MC24-12	12	56	36	11	19	46	10
MC24-15	15	64	41	12	21	60	10
MC24-18	18	68	42	14	22	75	10
MC24-22	22	74	46	16	25	98	10
MC24-28	28	84	51	19	28	133	4
MC24-35	35	100	57	24	31	184	2
MC24-42	42	114	65	27	35	268	2
MC24-54	54	138	75	34	40	423	1
MC24-67	66,7	200	100	50	50	970	1
MC24-76	76,1	230	109	60	54	1 170	1
MC24-89	88,9	260	125	67	62	1 600	1
MC24-108	108	310	146	79	70	2 394	1

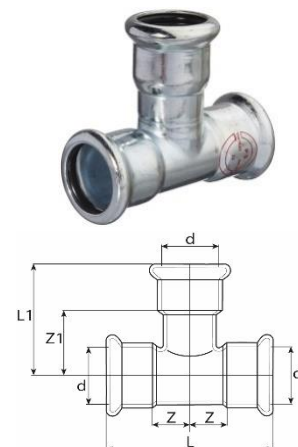

### Redukované t-spojky

Obj. č.	d (mm)	d1 (mm)	L (mm)	L1 (mm)	Z (mm)	Z1 (mm)	Hmotnost (g)	Balení (ks)
MC25-151215	15	12	64	40	12	23	52	10
MC25-181518	18	15	68	42	14	22	66	10
MC25-221522	22	15	74	44	16	24	89	10
MC25-221822	22	18	74	44	16	24	89	10
MC25-281528	28	15	84	47	19	27	118	10
MC25-281828	28	18	84	47	19	27	120	10
MC25-282228	28	22	84	49	19	28	127	10
MC25-351535	35	15	100	51	24,5	31	152	4
MC25-351835	35	18	100	51	24,5	31	156	4
MC25-352235	35	22	100	53	24,5	32	164	4
MC25-352835	35	28	100	55	24,5	32	174	4
MC25-422242	42	22	114	56	27,2	3	221	4
MC25-422842	42	28	114	58	27,2	35	227	4
MC25-423542	42	35	114	61	27,2	35,5	244	2
MC25-542254	54	22	138	62	34,5	41	322	1
MC25-542854	54	28	138	64	34,5	41	332	1
MC25-543554	54	35	138	67	34,5	41,5	364	1
MC25-544254	54	42	138	71	34,5	41,2	361	1
MC25-672867	66,7	28	200	72	50	49	828	1
MC25-673567	66,7	35	200	72	50	46	841	1
MC25-674267	66,7	42	200	76	50	46	871	1
MC25-675467	66,7	54	200	82	50	47	878	1
MC25-762276	76,1	22	230	74	60	53	984	1
MC25-762876	76,1	28	230	76	60	53	953	1
MC25-763576	76,1	35	230	76	60	50	968	1
MC25-764276	76,1	42	230	80	60	50	1 003	1
MC25-765476	76,1	54	230	86	60	51	1 005	1
MC25-766776	76,1	66,7	230	104	60	54	1 100	1
MC25-895489	89,9	54	260	93	67	58	1 376	1
MC25-897689	89,9	76,1	260	116	67	61	1 498	1
MC25-10854108	108	54	310	103	79	68	1 931	1
MC25-10867108	108	66,7	310	121	79	71	1 986	1
MC25-10876108	108	76,1	310	126	79	71	2 058	1
MC25-10889108	108	88,9	310	135	79	72	2 184	1

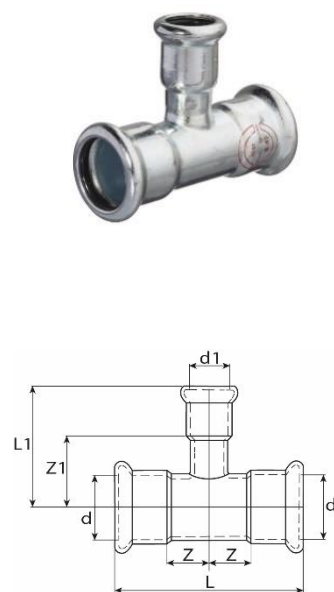



### Redukované t-spojky

Obj. č.	d (mm)	d1 (mm)	L (mm)	L1 (mm)	Z1 (mm)	Z2 (mm)	Z3 (mm)	Hmotnost (g)	Balení (ks)
MC27-221515	15	22	76	44	24	20	16	93	10
MC27-222215	22	15	77	46	25	16	19	98	10
MC27-282222	22	28	87,5	49	28	16	19	125	5
MC27-282822	28	22	88	51	28	19	26	130	5

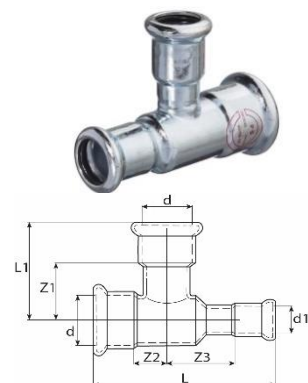

### Redukované t-spojky

Obj. č.	d (mm)	d1 (mm)	L (mm)	L1 (mm)	Z (mm)	Z1 (mm)	Hmotnost (g)	Balení (ks)
MC28-151815	15	18	63	41	12	21	67	10
MC28-152215	15	22	64	42	12	23	118	10
MC28-182218	18	22	68	45	14	24	81	10
MC28-222822	22	28	72	49	16	25	123	10

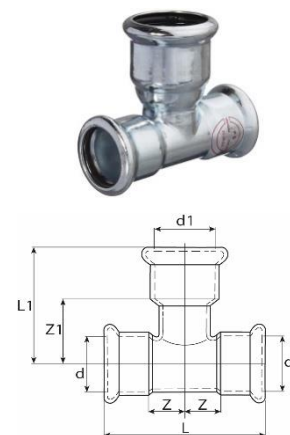

### T-spojky s vnitřním kuželovým závitem

Obj. č.	d (mm)	Rp	L (mm)	L1 (mm)	Z (mm)	Z1 (mm)	Hmotnost (g)	Balení (ks)
MC30-3812	12	3/8"	60	33	11	22,5	67	10
MC30-1215	15	1/2"	64	35	12	21,5	77	10
MC30-1218	18	1/2"	68	37	14	22	89	10
MC30-1222	22	1/2"	74	39	16	23,5	102	10
MC30-3422	22	3/4"	74	42	16	23,5	102	10
MC30-1228	28	1/2"	84	42	19	26,5	143	10
MC30-3428	28	3/4"	84	45	19	26,5	156	10
MC30-1235	35	1/2"	100	46	24,5	30,5	170	4
MC30-3435	35	3/4"	100	50	24,5	30,5	170	2
MC30-1242	42	1/2"	114	49	27,2	33,5	221	2
MC30-3442	42	3/4"	114	53	27,2	33,5	221	1
MC30-1254	54	1/2"	138	55	34,6	39,5	352	1
MC30-3454	54	3/4"	138	60	34,6	39,5	355	1
MC30-3467	67	3/4"	200	70	50	63	825	1
MC30-3476	76	3/4"	230	78	60	67	950	1
MC30-3489	89	3/4"	260	78	67	74	1 240	1
MC30-34108	108	3/4"	310	85	79	84	1 830	1

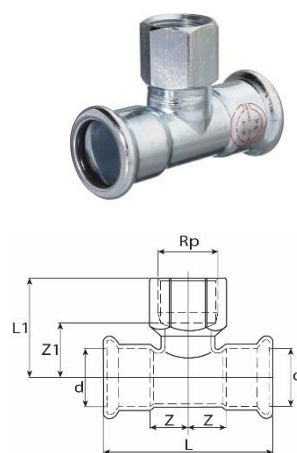



### Záslepky

Obj. č.	d (mm)	L (mm)	Hmotnost (g)	Balení (ks)
MC61-12	12	28	18	10
MC61-15	15	29	22	10
MC61-18	18	29	27	10
MC61-22	22	30	36	10
MC61-28	28	30	48	10
MC61-35	35	34	52	4
MC61-42	42	45	109	4
MC61-54	54	48,8	138	2

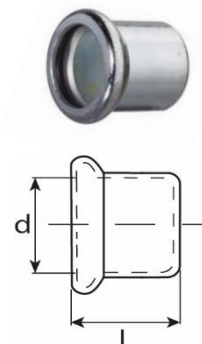

### Přímá šroubení s vnitřním kuželovým závitem

Obj. č.	d (mm)	L (mm)	Z (mm)	Rp	Hmotnost (g)	Balení (ks)
MC62-3415	15	47	20	3/4"	81	10
MC62-3418	18	47	20	3/4"	83	10
MC62-1022	22	50	21	1"	139	10
MC62-5428	28	54	23	1-1/4"	186	4
MC62-1535	35	57	26	1-1/2"	265	4

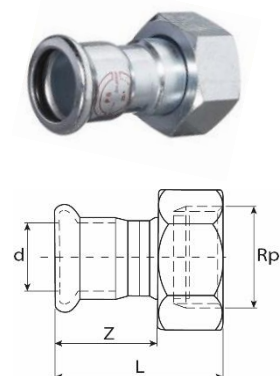

### Přímá šroubení s vnějším kuželovým závitem

Obj. č.	d (mm)	L (mm)	Z (mm)	R	Hmotnost (g)	Balení (ks)
MC69-1215	15	72	20	1/2"	150	5
MC69-1218	18	70	20	1/2"	165	5
MC69-3422	22	75	21	3/4"	245	5
MC69-1028	28	82	23	1"	394	4
MC69-5435	35	89	26	1-1/4"	544	4
MC69-1542	42	93	30	1-1/2"	647	2
MC69-2054	54	109	35	2"	939	1

