

Standard executions		
Version	Symbol	Type
Standard		ARTM
Flanged		ARTMF
Magnetic		ARTMC
Flanged magnetic		ARTMFC
Standard with adjustable angle		ARTML
Flanged with adjustable angle		ARTMFL
Magnetic with adjustable angle		ARTMLC
Flanged magnetic with adjustable angle		ARTMFLC

New



1

Series of Hi-rotor cylinders with fixed and adjustable rotation angles and reduced overall dimensions. They are provided with elastic dampers to relieve the impacts of the vanes.

Options	Suffix
Special versions on request	/ S

How to order: 20 / 90° ARTML

15	/	90°	ARTML
Size	/	Rotation	Type

Technical data						
Size		10	15	20	30	40
Bores		Ø 4	Ø 5	Ø 6	Ø 8	Ø 10
Fluid	Compressed filtered air with or without lubrication. Lubrication, if be used, must be continuous					
Pressure range	1,5 ÷ 7 bar					
Temperature range	0° C ÷ + 50° C					
Rotation angle	90° - 180° - 270°					
Torque moment (Nm)		0,14	0,38	0,78	1,8	3,8
Ports	M5					
Weight (g)	ARTM	28	48	112	200	342
	ARTMF	41	70	138	268	438
	ARTMFC	78	116	240	390	604
	ARTMFLC	91	138	266	468	700

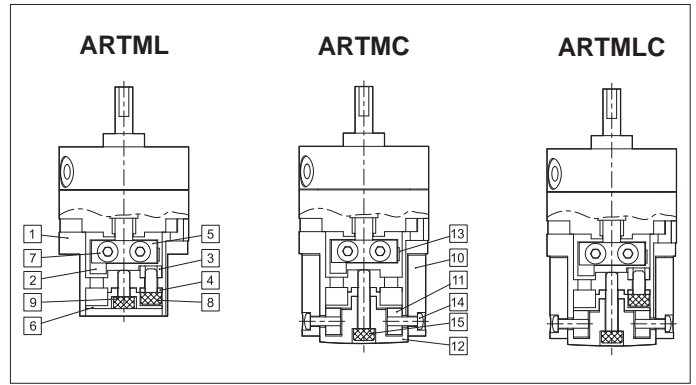
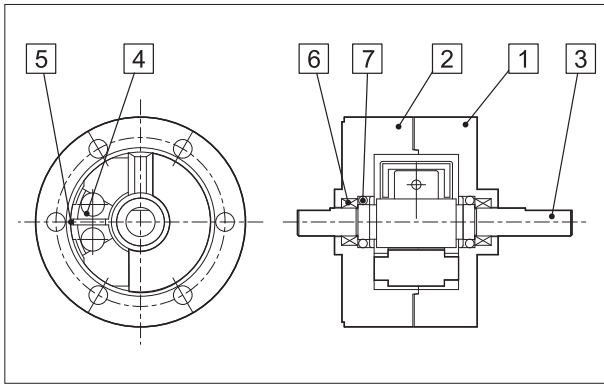

### Materials (standard types)

1	Front cover	Aluminium alloy
2	End cover	Aluminium alloy
3	Rod	Steel alloy
4	Stopper	Plastic - Steel
5	O-ring	Nitrilic rubber NBR
6	Bearing	Steel
7	O-ring	Nitrilic rubber NBR

### Materials (standard types)

1	Position base	Zinc alloy
2	Position lump	Stainless steel
3	Angle location lump	Steel
4	Angle location slice	Steel
5	Lump	Stainless steel
6	End cover	Aluminium
7	Screw	Steel alloy
8	Screw	Steel alloy
9	Screw	Steel alloy
10	Mounting base	Aluminium alloy
11	Base and lump	Aluminium alloy
12	End cover	Aluminium alloy
13	Magnet	TME
14	Screw	Lega di acciaio
15	Screw	Lega di acciaio

### Output torque table

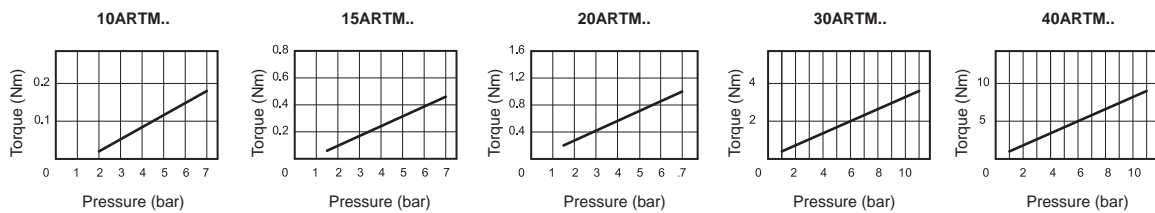

### Rotation angle

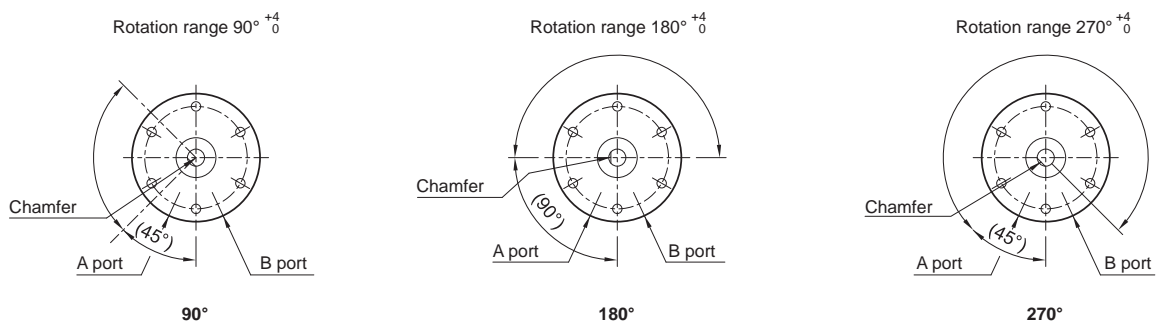

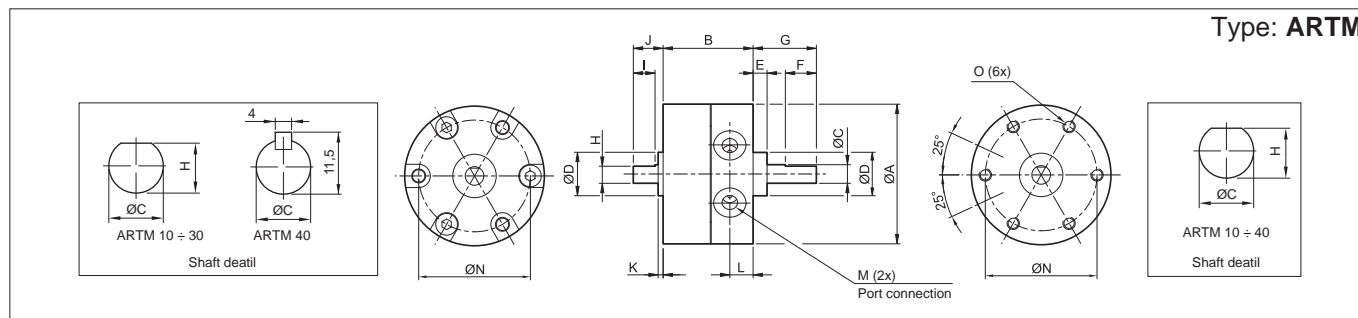

Item	A	B	C	D	E	F	G	H	I	J	K	L	M	N	O
10/90ARTM	30	17	4	9	3	9	14	3,5	5	8	1	4,2	M5x0,8p	24	M3x0,5p
10/180ARTM															
10/270ARTM															
15/90ARTM	35	20,1	5	12	4	10	18	4,5	6	9	1,5	5	M5x0,8p	29	M3x0,5p
15/180ARTM															
15/270ARTM															
20/90ARTM	44	29,1	6	14	4,5	10	20,3	5,5	7	9,6	1,6	8,5	M5x0,8p	36	M3x0,5p
20/180ARTM															
20/270ARTM															
30/90ARTM	51	40	8	16	5	12	22	7,5	8	13	2	11	M5x0,8p	43	M3x0,5p
30/180ARTM															
30/270ARTM															
40/90ARTM	64	45	10	25	6,5	22	30	9	9	15	4,5	9,5	M5x0,8p	56	M3x0,5p
40/180ARTM															
40/270ARTM															

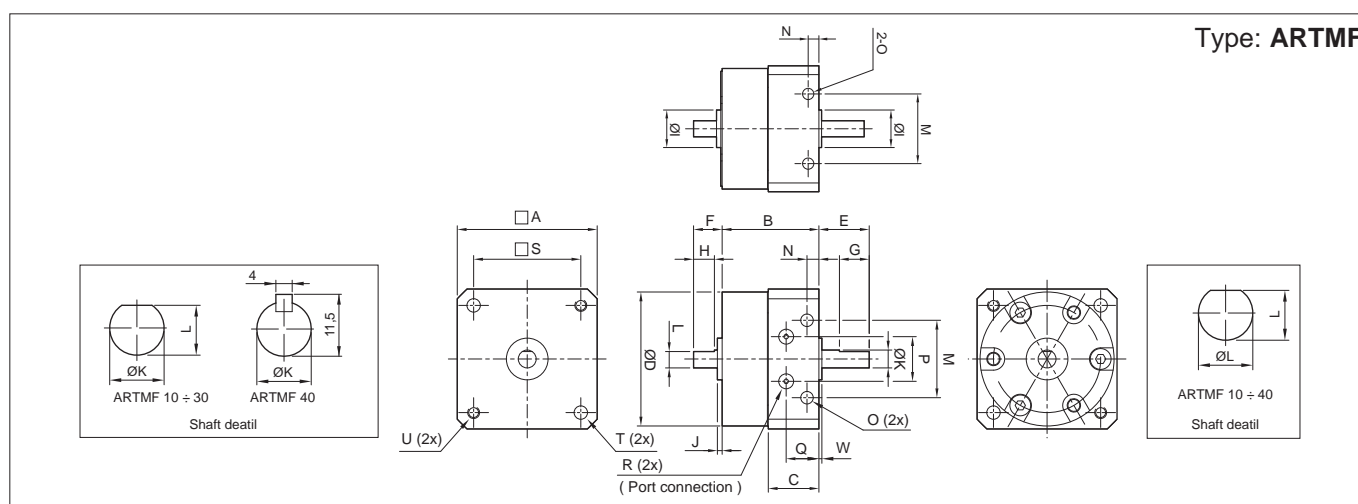

Item	A	B	C	D	E	F	G	H	I	J	K	L	M	N	O	P	Q	R	S	T	U	V	W
10/90ARTMF	31	22	13,3	30	14	8	9	5	9	1	4	3,5	17	3	3,5	10,5	9,2	M5x0,8p	25	3,5	M3x0,5p	24	1
10/180ARTMF																							
10/270ARTMF																							
15/90ARTMF	36	25,7	15,5	35	18	9	10	6	12	1,5	5	4,5	21	3	3,5	10,5	10,5	M5x0,8p	29	3,5	M3x0,5p	29	1,5
15/180ARTMF																							
15/270ARTMF																							
20/90ARTMF	44	33,6	19	44	20	10	10	7	14	1,6	6	5,5	26	4	4,2	15	13	M5x0,8p	36	4,5	M3x0,5p	36	1
20/180ARTMF																							
20/270ARTMF																							
30/90ARTMF	52	47,5	27,2	51	22	13	12	8	16	2	8	7,5	29	4,5	5,5	13,5	18,5	M5x0,8p	42	5,5	M3x0,5p	43	2
30/180ARTMF																							
30/270ARTMF																							
40/90ARTMF	64	53	30,4	64	30	15	22	9	25	4,5	10	9	38	5	5,5	19	14	M5x0,8p	52	5,5	M3x0,5p	56	3
40/180ARTMF																							
40/270ARTMF																							

# Hi-Rotary Cylinders

Bores: 4, 5, 6, 8, 10 mm

Standard dimensions

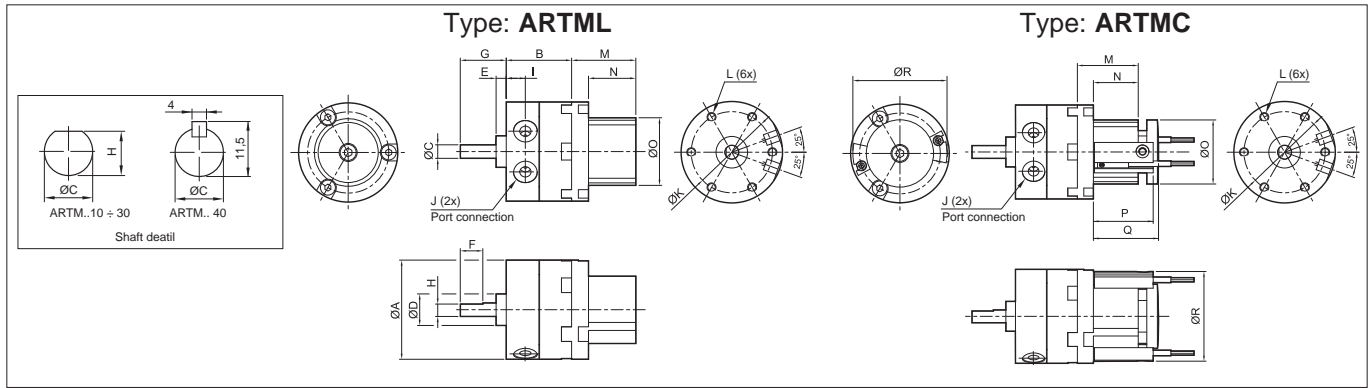

Item	A	B	C	D	E	F	G	H	I	J	K	L	M	N	O	P	Q	R
10/90ARTML 10/90ARTMC	30	17	4	9	3	9	14	3,5	4,2	M5x0,8p	24	M3x0,5p	24	18	18	23,3	24	29
10/180ARTML 10/180ARTMC																		
10/270ARTML 10/270ARTMC																		
15/90ARTML 15/90ARTMC																		
15/180ARTML 15/180ARTMC	35	20,1	5	12	4	10	18	4,5	5	M5x0,8p	29	M3x0,5p	28	22	24	27,3	29,5	34
15/270ARTML 15/270ARTMC																		
20/90ARTML 20/90ARTMC																		
20/180ARTML 20/180ARTMC	44	29,1	6	14	4,5	10	20,3	5,5	8,5	M5x0,8p	36	M3x0,5p	28,5	21	30	28	30,5	42
20/270ARTML 20/270ARTMC																		
30/90ARTML 30/90ARTMC																		
30/180ARTML 30/180ARTMC	51	40	8	16	5	12	22	7,5	11	M5x0,8p	43	M3x0,5p	32,5	24	34	30,8	34	47
30/270ARTML 30/270ARTMC																		
40/90ARTML 40/90ARTMC																		
40/180ARTML 40/180ARTMC	64	45	10	25	6,5	22	30	-	9,5	M5x0,8p	56	M3x0,5p	34,5	26	34	33	36	47
40/270ARTML 40/270ARTMC																		

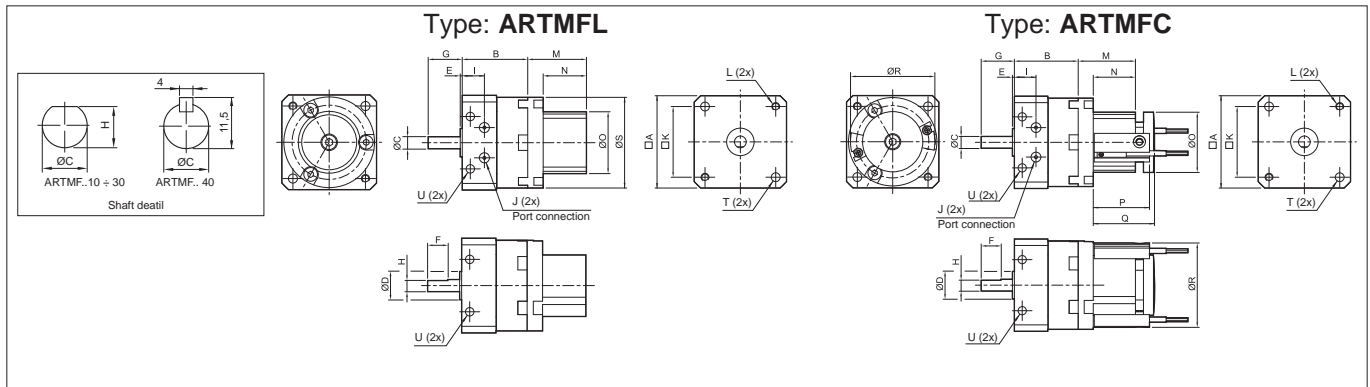

Item	A	B	C	D	E	F	G	H	I	J	K	L	M	N	O	P	Q	R	S	T	U
10/90ARTMFL 10/90ARTMFC	31	22	4	9	1	9	14	3,5	9,2	M5x0,8p	25	M3x0,5p	24	18	18	23,3	24	29	30	3,5	3,5
10/180ARTMFL 10/180ARTMFC																					
10/270ARTMFL 10/270ARTMFC																					
15/90ARTMFL 15/90ARTMFC																					
15/180ARTMFL 15/180ARTMFC	36	25,7	5	12	1,5	10	18	4,5	10,5	M5x0,8p	29	M3x0,5p	28	22	24	27,3	29,5	34	35	3,5	3,5
15/270ARTMFL 15/270ARTMFC																					
20/90ARTMFL 20/90ARTMFC																					
20/180ARTMFL 20/180ARTMFC	44	33,6	6	14	1	10	20	5,5	13	M5x0,8p	36	M3x0,5p	28,5	21	30	28	30,5	42	44	4,5	4,2
20/270ARTMFL 20/270ARTMFC																					
30/90ARTMFL 30/90ARTMFC																					
30/180ARTMFL 30/180ARTMFC	52	47,5	8	16	2	12	22	7,5	18,5	M5x0,8p	42	M3x0,5p	32,5	24	34	30,8	34	47	51	5,5	5,5
30/270ARTMFL 30/270ARTMFC																					
40/90ARTMFL 40/90ARTMFC																					
40/180ARTMFL 40/180ARTMFC	64	53	10	25	3	22	30	-	14	M5x0,8p	52	M3x0,5p	34,5	26	34	33	36	47	64	5,5	5,5
40/270ARTMFL 40/270ARTMFC																					

Esecuzioni standard		
Version	Symbol	Type
Standard		ARTM
Magnetic		ARTMC
Standard adjustable angle		ARTML
Magnetic adjustable angle		ARTMLC

New



1

Series of Hi-rotor cylinders with fixed and adjustable rotation angles and reduced overall dimensions. They are provided with elastic dampers to relieve the impacts of the vanes.

For mounting accessories see from page 1.50.10.

How to order: 15 / 90° ARTML

Options	Suffix
With shock absorber	D
Special versions on request	/ S

15	/	90°	ARTML
Size	/	Rotation	Type

Technical data					
Size	50	63	80	100	
Bores	Ø 12	Ø 15	Ø 17	Ø 25	
Fluid	Compressed filtered air with or without lubrication. Lubrication, if started, must be continued.				
Pressure range	1,5 ÷ 7 bar				
Temperature range	0° C ÷ + 50° C				
Rotation angle	90° - 180° - 270°				
Torque moment (Nm)	5	10	18	35	
Ports	1/8"		1/4"		
Weight (g)	ARTM	760	1290	1920	3560
	ARTMC	1100	1150	2300	3900

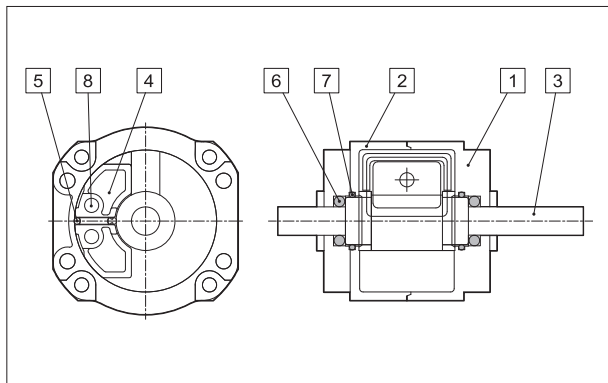

Materials (standard types)		
1	Front body	Aluminium alloy
2	End body	Aluminium alloy
3	Rod	Steel alloy
4	Position block	Aluminium alloy
5	O-ring	Nitrilic rubber NBR
6	Bearing	Steel
7	O-ring	Nitrilic rubber NBR
8	Position pin	Steel

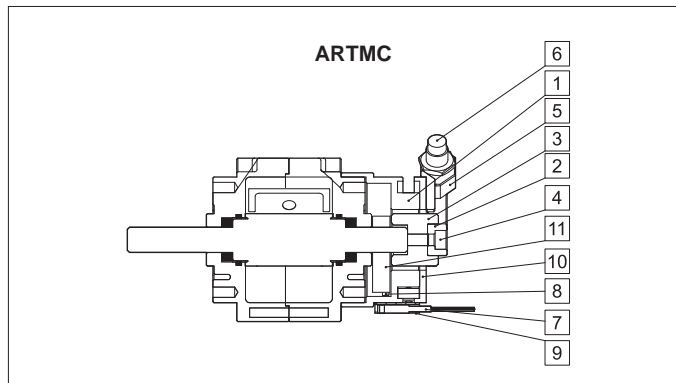

Materials (standard types)		
1	Position base	Aluminium alloy
2	Rocker arm	Stainless steel
3	Rocker arm seat	Stainless steel
4	Screw	Steel alloy
5	Angle adjustment	Aluminium alloy
6	Shock absorber	-
7	Sensor switch	-
8	Magnet	Rare earth materials
9	Mounting base	Aluminium alloy
10	End cover	Aluminium alloy
11	Magnet seat	Aluminium alloy

## Output torque table

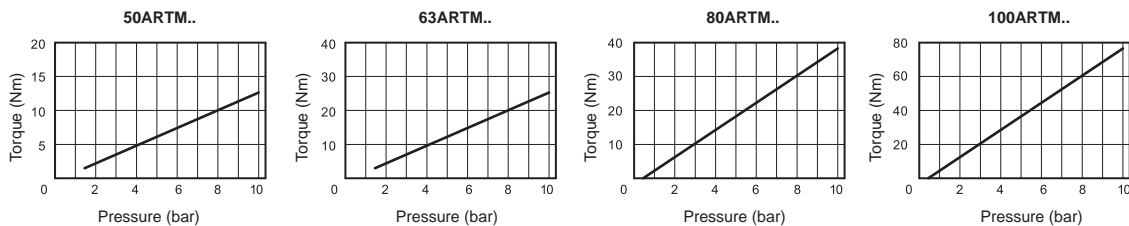

## Rotation angle

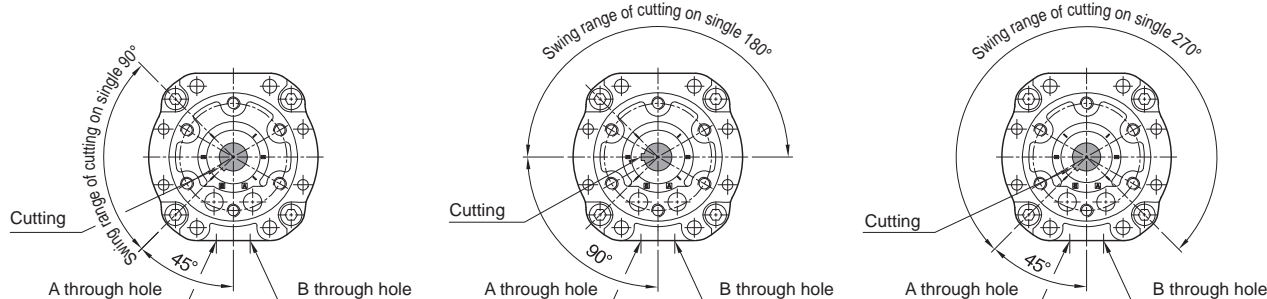

Type: ARTM

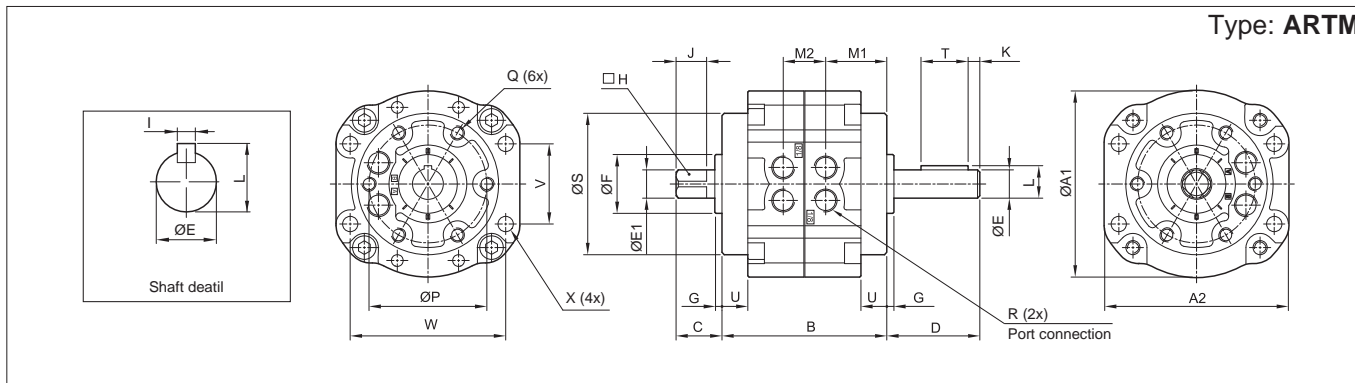

Item	A1	A2	B	C	D	E	F	G	H	I	J	K	L	M1	M2	P	Q	R	S	T	U	V	W	ØX
50/90ARTM	79	78	70	19,5	39,5	12	25	3	10	4	13	5	13,5	26	18,2	50	M6x1,0p	RC1/8"	60	20	11	34	66	6,5
50/180ARTM																								
50/270ARTM																								
63/90ARTM	98	98	80	21	45	15	28	3	12	5	14	5	17	28,9	22,2	60	M8x1,25p	RC1/8"	75	25	14	39	83	9
63/180ARTM																								
63/270ARTM																								
80/90ARTM	110	110	90	23,5	53,5	17	30	3	13	5	16	5	19	30	30,2	70	M8x1,25p	RC1/4"	88	41	15	48	94	9
80/180ARTM																								
80/270ARTM																								
100/90ARTM	140	140	103	30	65	25	45	4	19	7	22	5	28	35,4	32,2	80	M10x1,5p	RC1/4"	108	40	11,5	60	120	11
100/180ARTM																								
100/270ARTM																								

Type: ARTMC

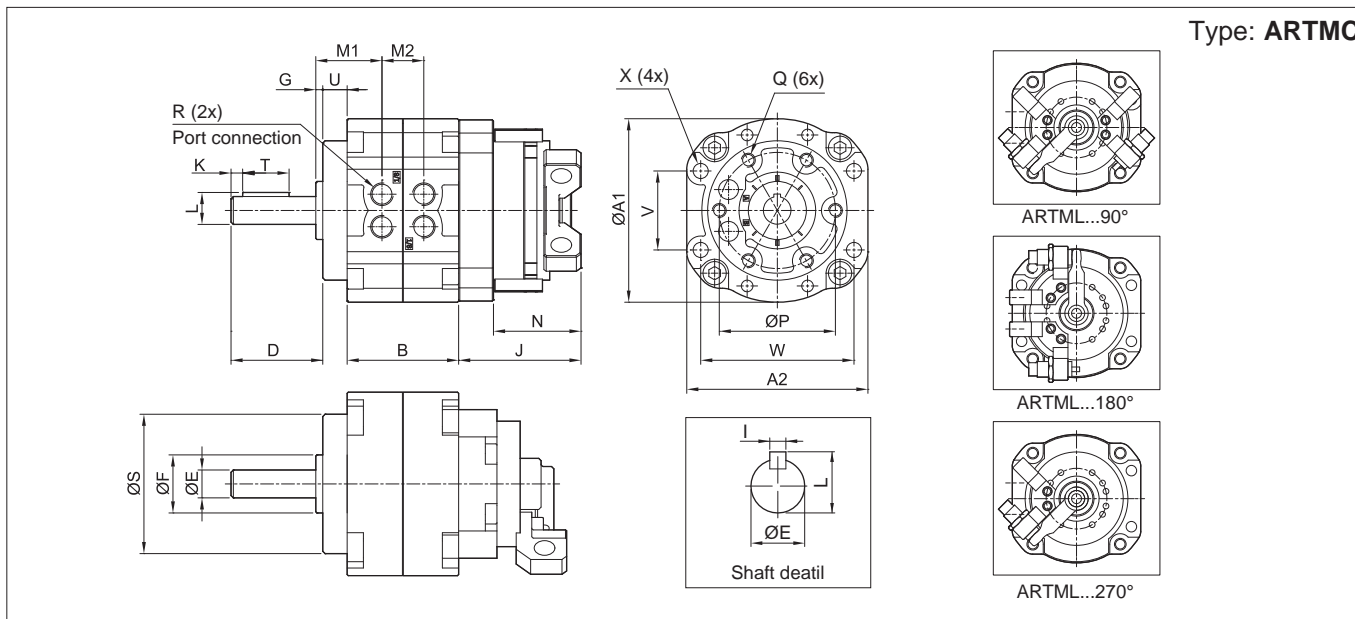

Item	A1	A2	B	D	E	F	G	I	J	K	L	M1	M2	N	P	Q	R	S	T	U	V	W	ØX
50/90ARTMC	79	78	48	50,5	12	25	3	4	52,7	5	13,5	29	18	37,7	50	M6x1,0p	RC1/8"	60	20	11	34	66	6,5
50/180ARTMC																							
50/270ARTMC																							
63/90ARTMC	98	98	52	59	15	28	3	5	56,4	5	17	31,9	22,2	37,7	60	M8x1,25p	RC1/8"	75	25	14	39	83	9
63/180ARTMC																							
63/270ARTMC																							
80/90ARTMC	110	110	60	68,5	17	30	3	5	58,9	5	19	33	30	39,2	70	M8x1,25p	RC1/4"	88	36	15	48	94	9
80/180ARTMC																							
80/270ARTMC																							
100/90ARTMC	140	140	80	76,5	25	45	4	7	62,9	5	28	39,4	32,2	39,2	90	M10x1,5p	RC1/4"	108	40	11,5	60	120	11
100/180ARTMC																							
100/270ARTMC																							

