

# Rotary actuators series ARC

## Bores from 10 to 63 mm

Double acting



Standard executions		
Version	Code	Item
Bore 10 mm (x2)	075581	10ARC
Bore 12 mm (x2)	075582	12ARC
Bore 15 mm (x2)	073063	15ARC
Bore 18 mm (x2)	073064	18ARC
Bore 20 mm (x2)	073065	20ARC
Bore 25 mm (x2)	073066	25ARC
Bore 28 mm (x2)	075583	28ARC
Bore 32 mm (x2)	075584 <i>New</i>	32ARC
Bore 40 mm (x2)	075585 <i>New</i>	40ARC
Bore 50 mm (x2)	075586 <i>New</i>	50ARC
Bore 63 mm (x2)	075587 <i>New</i>	63ARC



Options	Suffix
With hydraulic shock absorbers	D

### How to choose the shock absorber

Rotary actuator	Cushioning capability max (kgf.m)
15ARC	3
18ARC	6
20ARC	6
25ARC	20
28ARC	59
32ARC	59
40ARC	147
50ARC	147
63ARC	147

Series of rotary actuators with double rack with rotation angles 90°-180° and adjustment angle from 0°±90°.

They are standard magnetic provided with grooves on the body allowing the direct mounting of the magnetic reed switches. The mechanical stoppers are standard; the hydraulic shock absorbers can be supplied on request.

For the magnetic reed switches type ASC see from page 1.110.1

How to order: 20ARCD

20	ARC	D
Bore	Item	Option

Technical data											
Type	10	12	15	18	20	25	28	32	40	50	63
Bore	Ø 10	Ø 12	Ø 15	Ø 18	Ø 20	Ø 25	Ø 28	Ø 32	Ø 40	Ø 50	Ø 63
Fluid	Compressed filtered air with or without lubrication. Lubrication, if started, must be continued.										
Pressure range	1,5 ÷ 7 bar										
Temperature range	0° C ÷ + 50° C										
Rotation angle	180°										
Adjustment angle	0° ÷ 190°										
Rotation moments (Nm)	0,3	0,6	1,5	2,2	3,2	5,5	7,5	9,8	19	31	45
Ports	M3		M5			1/8"					
Weight (g)	150	250	530	990	1290	2100	2890	4100	7650	8960	11170

Materials

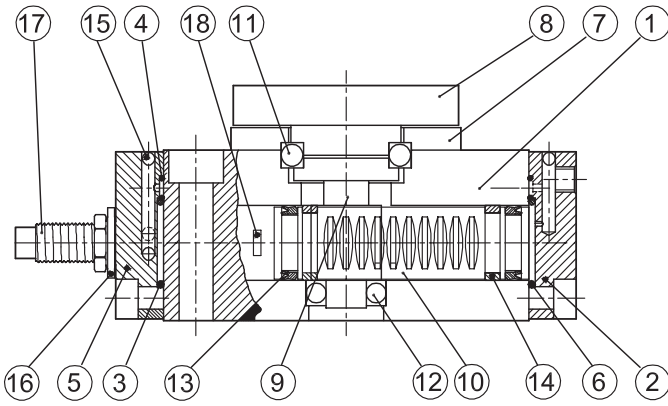

N.	Component	Material
1	Body	Anodised aluminium
2	Front head	Anodised aluminium
3	O-Ring	NBR
4	O-Ring	NBR
5	Rear head	Anodised aluminium
6	O-Ring	NBR
7	Bearings cover	Anodised aluminium
8	Rotating plate	Anodised aluminium
9	Piston rod	Hardned steel
10	Rack	Stainless steel
11	Spherical bearing	Steel
12	Spherical bearing	Steel
13	Piston seal	NBR
14	Washer	Plastic material
15	Ball	Steel alloy
16	Limit switch seal	NBR
17	Mechanical stopper	Steel alloy
18	Magnet	Metal

Direction and rotation angle

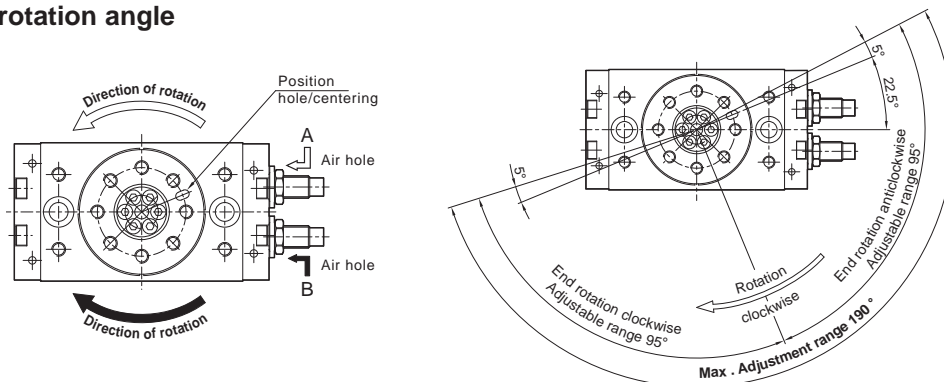

Rotation angles

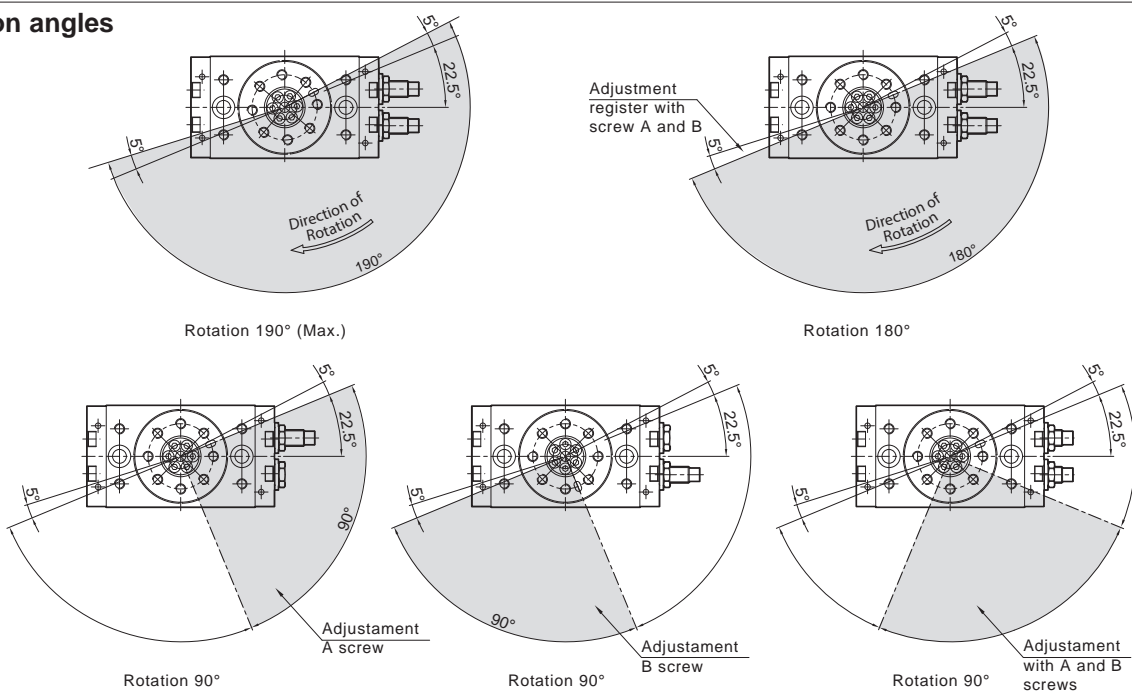

Possible loads				
Type	Kind of loads	Top (N)		Torque moment (N)
		(a)	(b)	
Load	Side (N)	(a)	(b)	Torque moment (N)
10ARC	33	48	48	1,1
12ARC	54	71	71	1,5
15ARC	70	78	74	2
18ARC	140	130	130	3,5
20ARC	185	188	358	4,8
25ARC	300	285	442	9
28ARC	333	296	476	12
32ARC	390	493	706	18
40ARC	543	740	1009	25
50ARC	850	950	1500	30
63ARC	1200	1400	2100	38

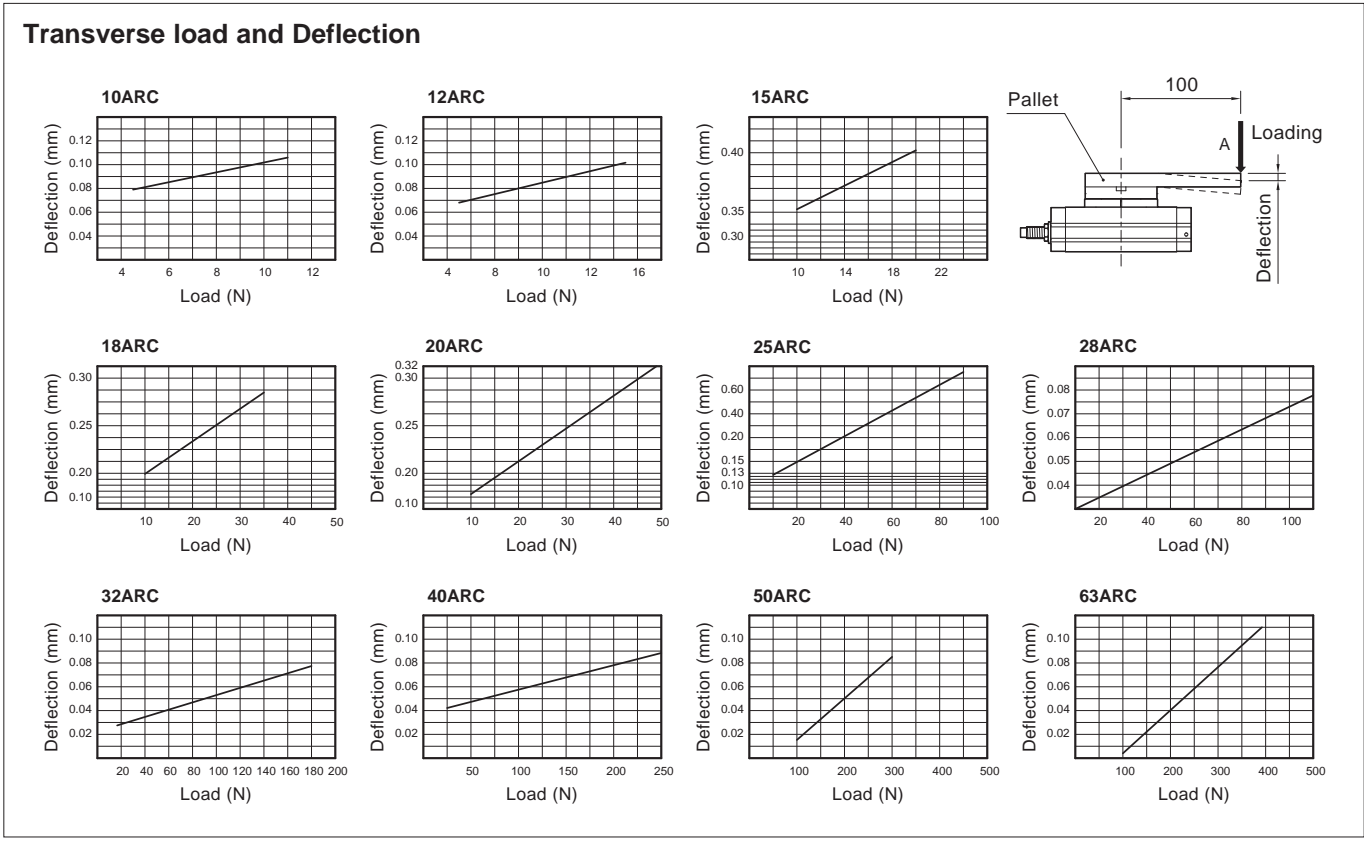

# Rotary actuators series ARC

Bores from 10 to 63 mm

Standard dimensions



## Type: 10ARC

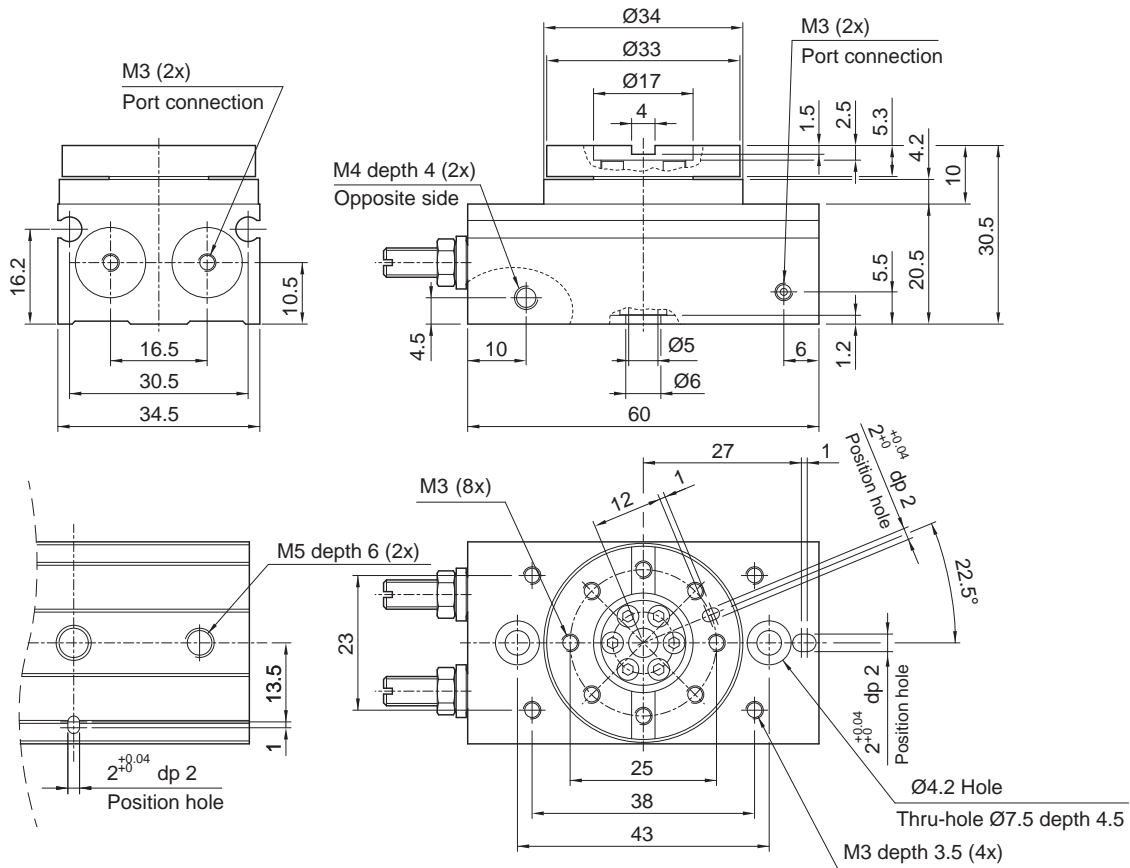

## Type: 12ARC

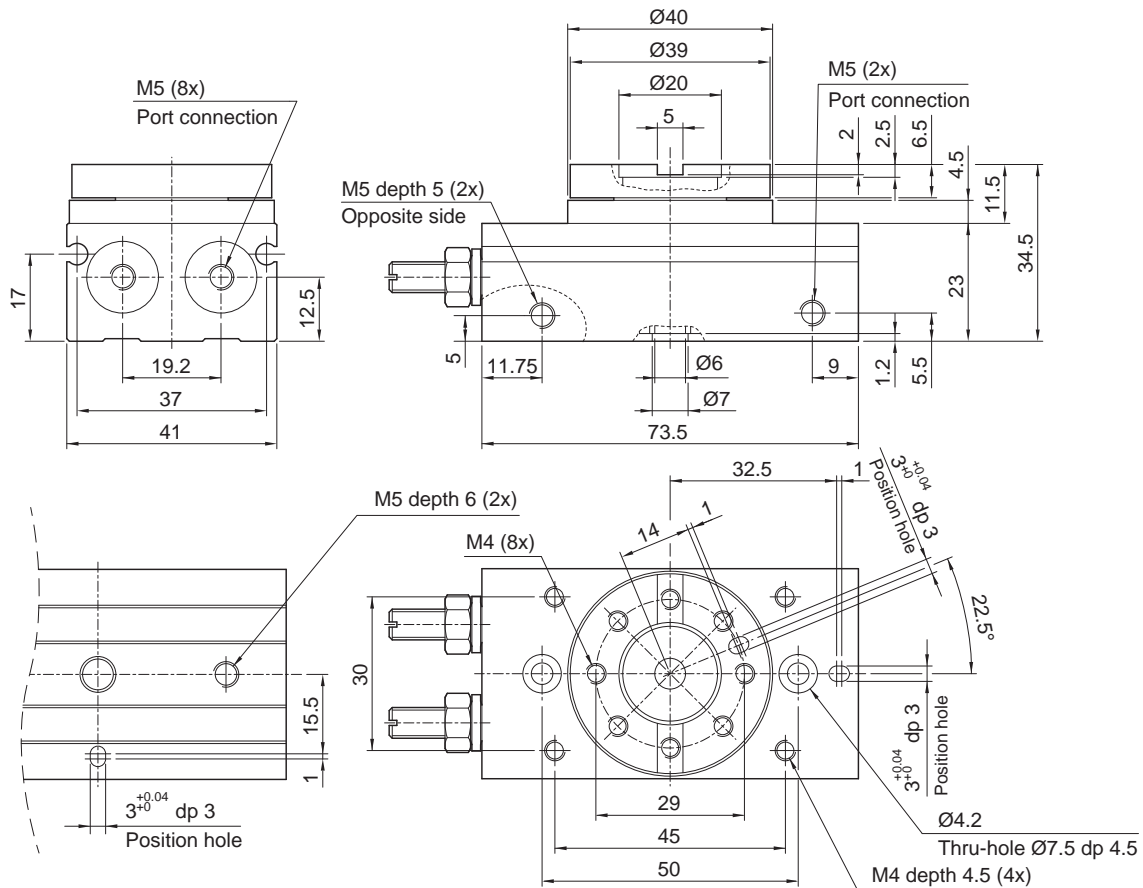

Type: 15ARC

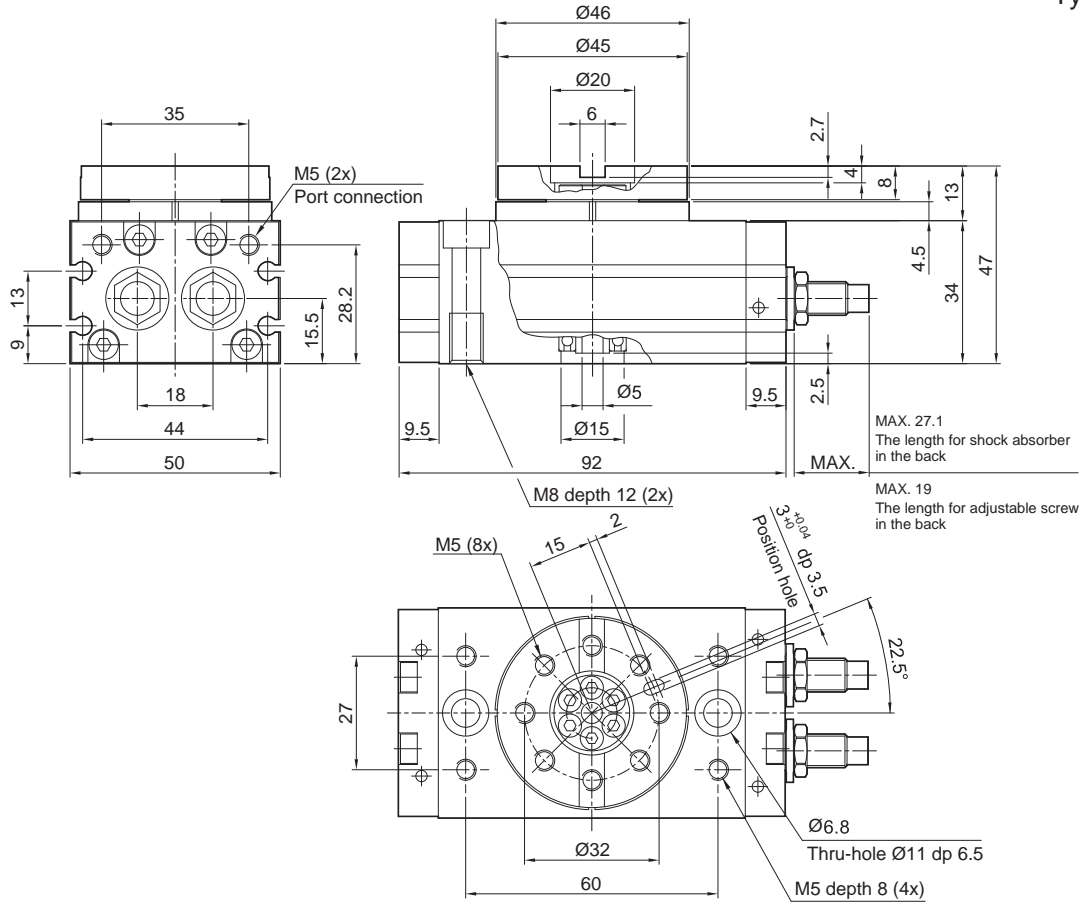

Type: 18ARC

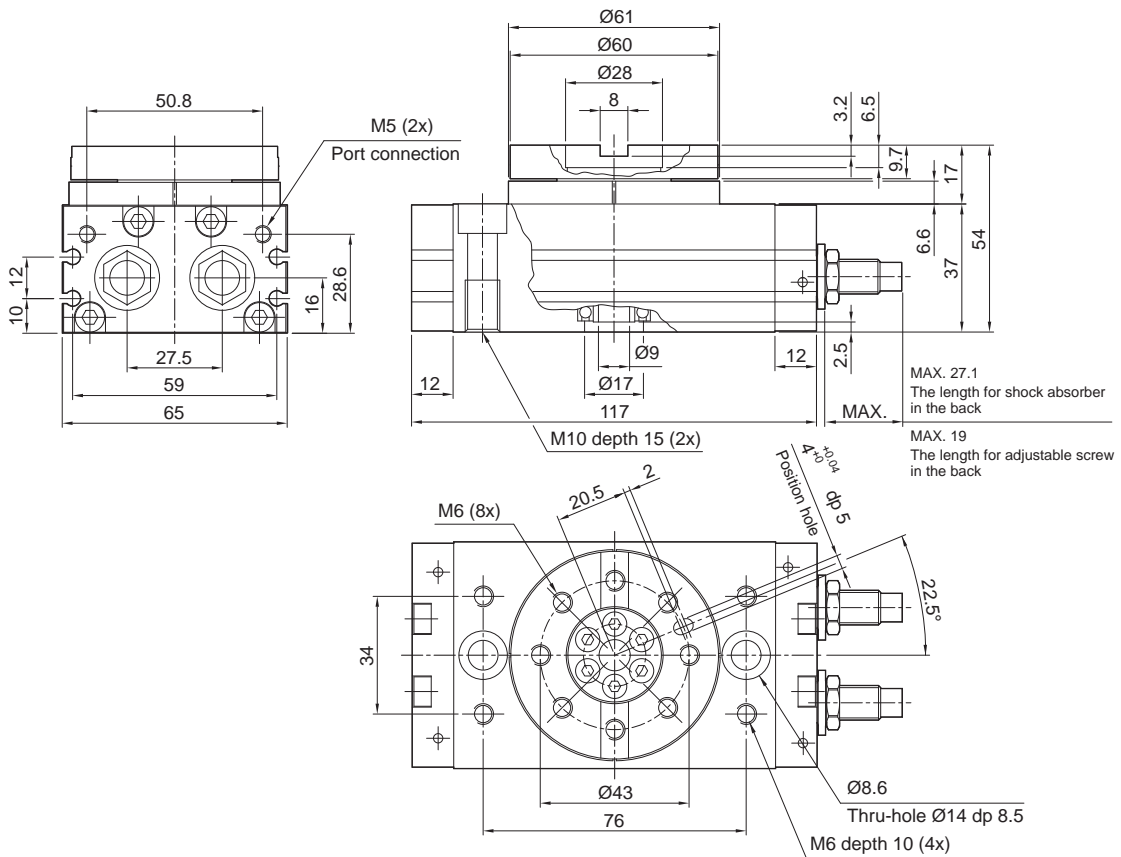

# Rotary actuators series ARC

Bores from 10 to 63 mm

Standard dimensions



## Type: 20ARC

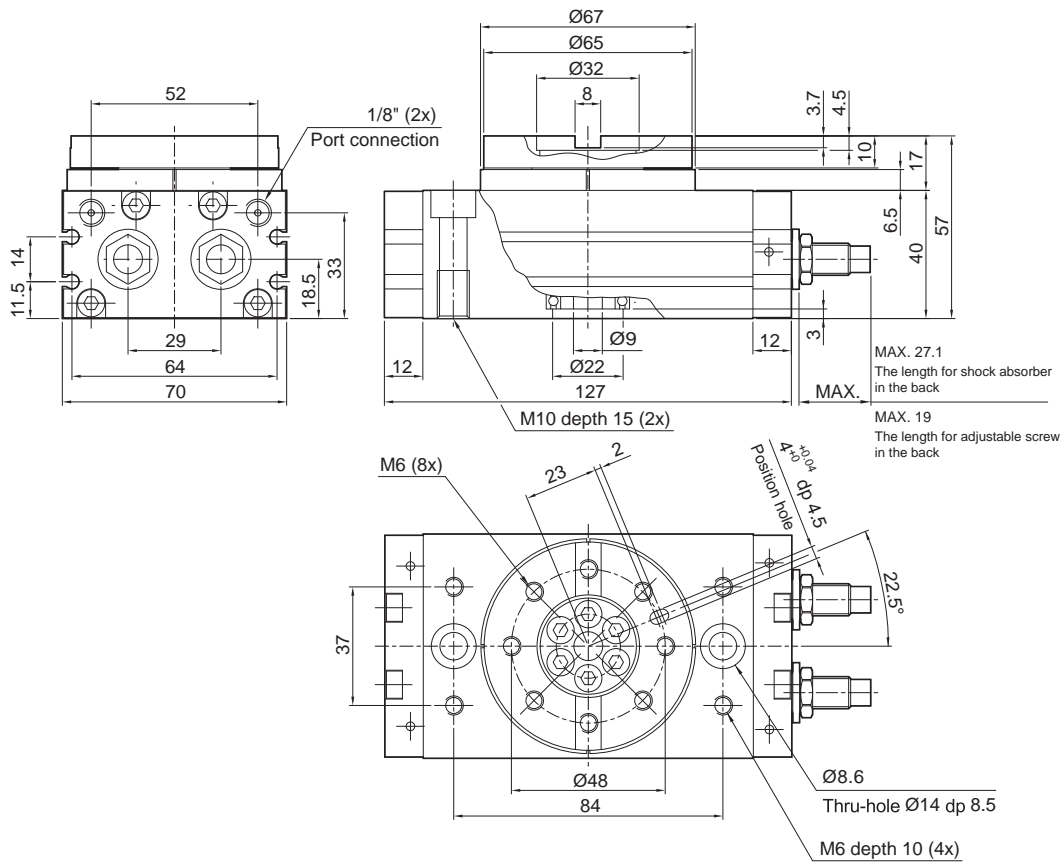

## Type: 25ARC

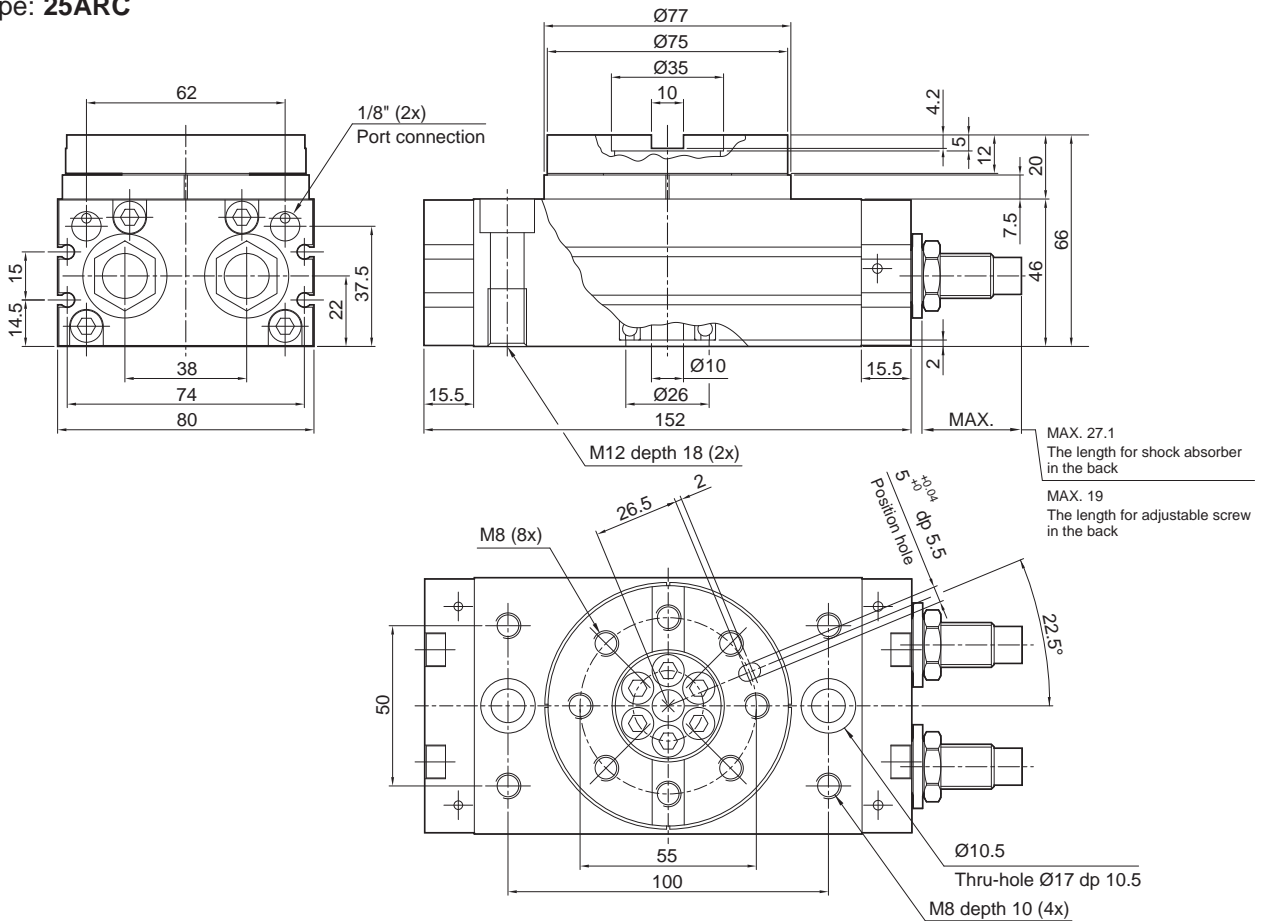

Rotary actuators series ARC  
Bores from 10 to 63 mm *Standard dimensions*



Type: **28ARC**

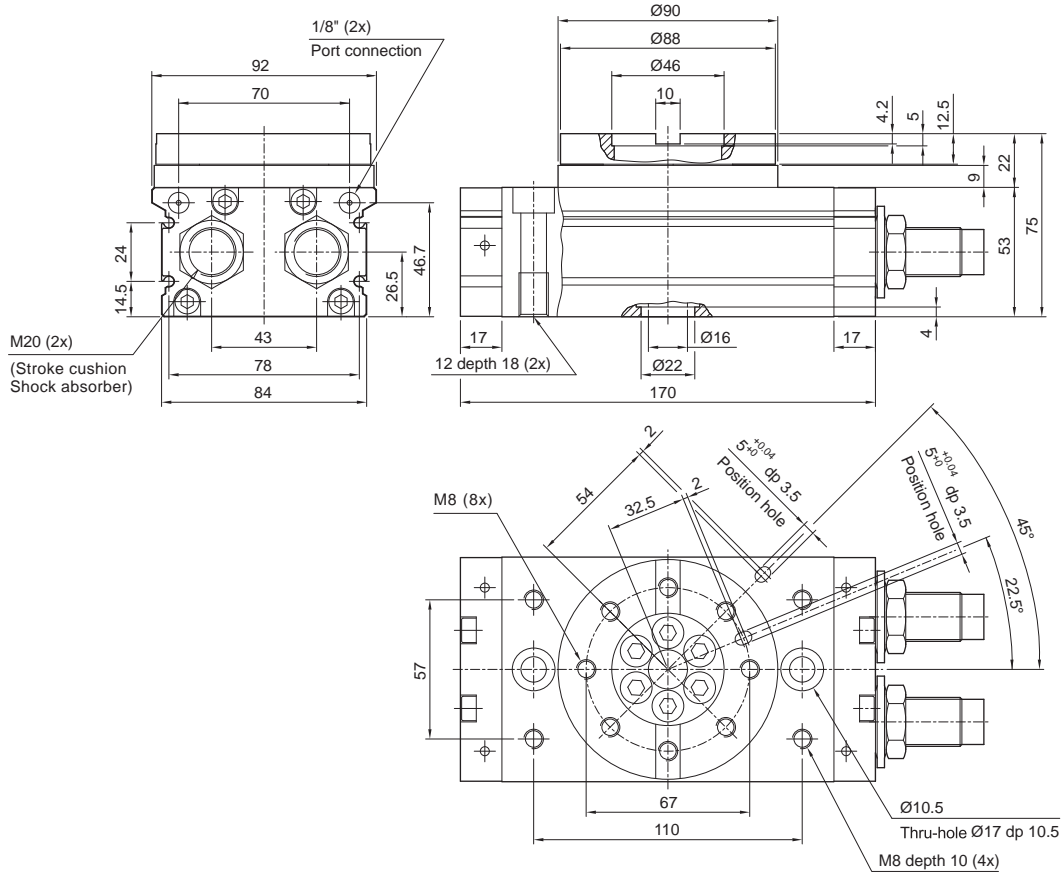

Type: **32ARC**

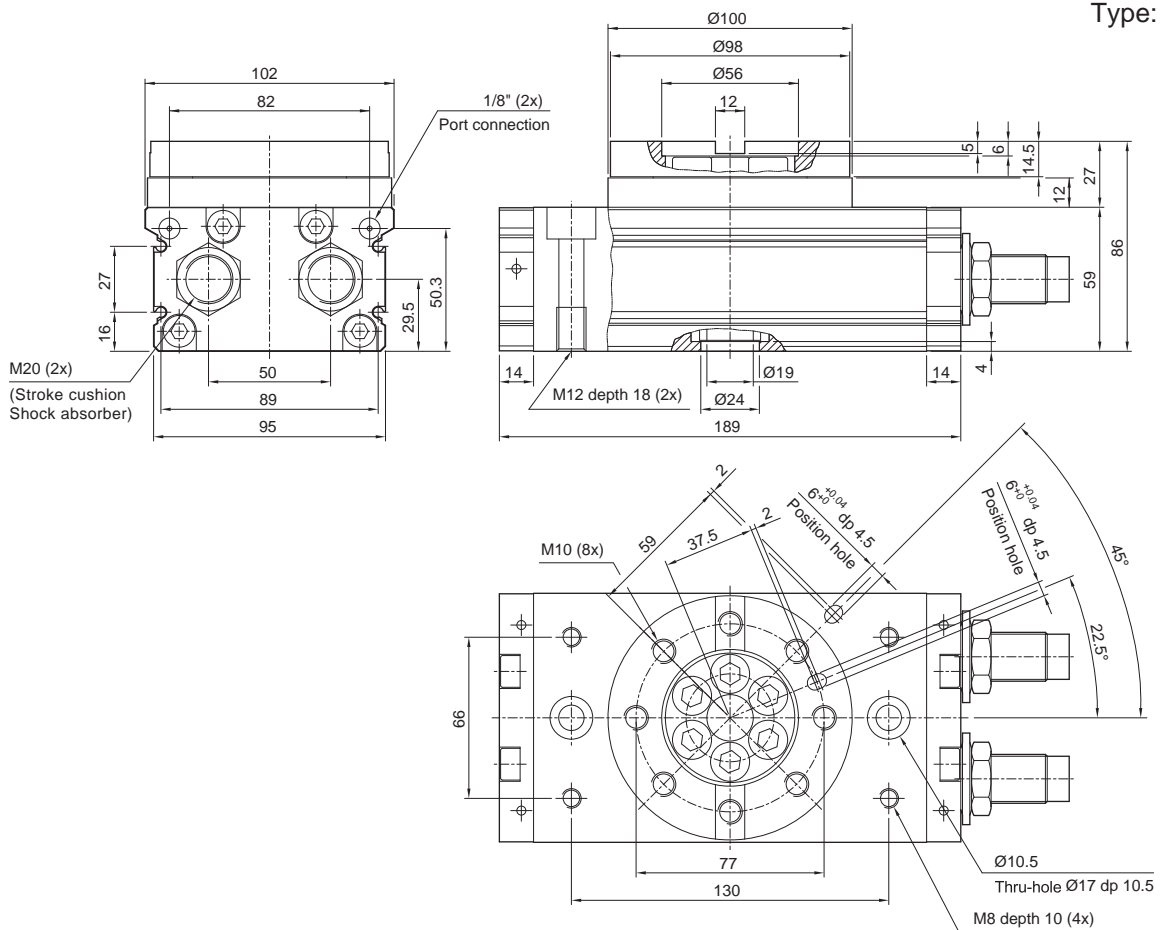

Rotary actuators series ARC  
Bores from 10 to 63 mm *Standard dimensions*



Type: **40ARC**

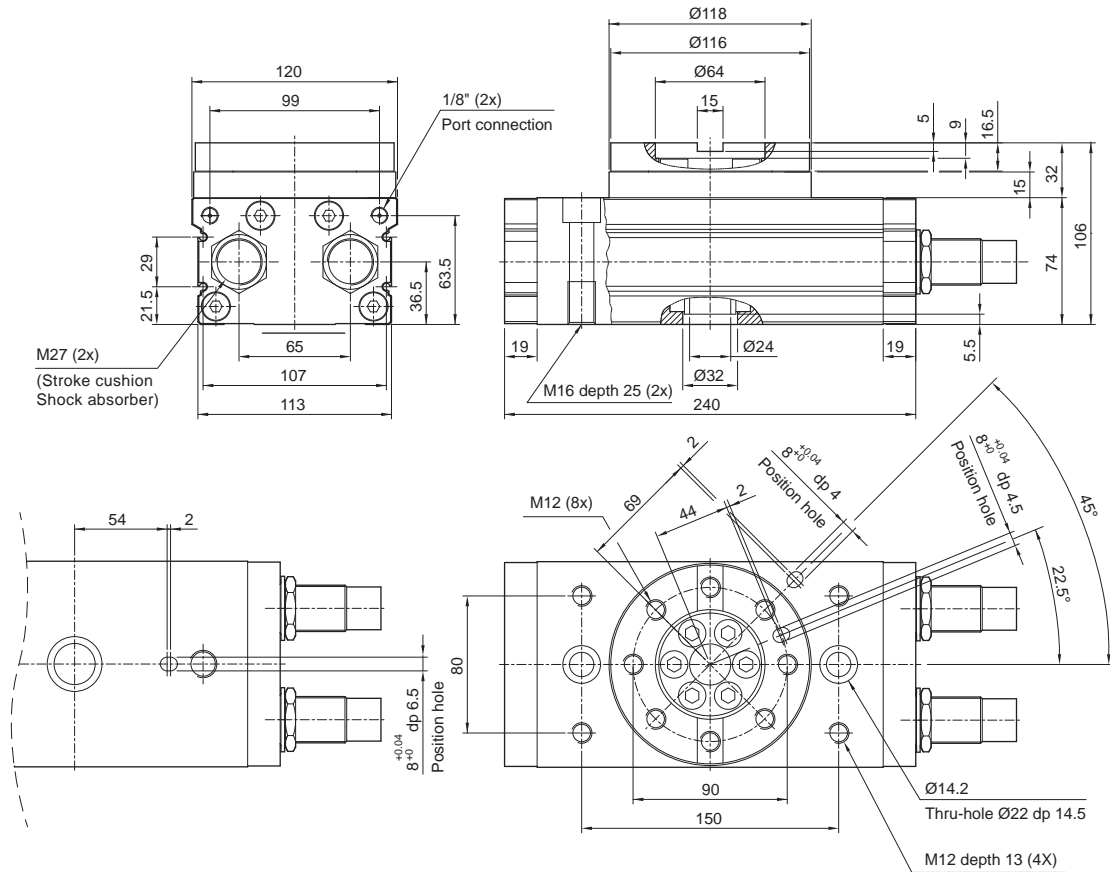

Type: **50ARC**

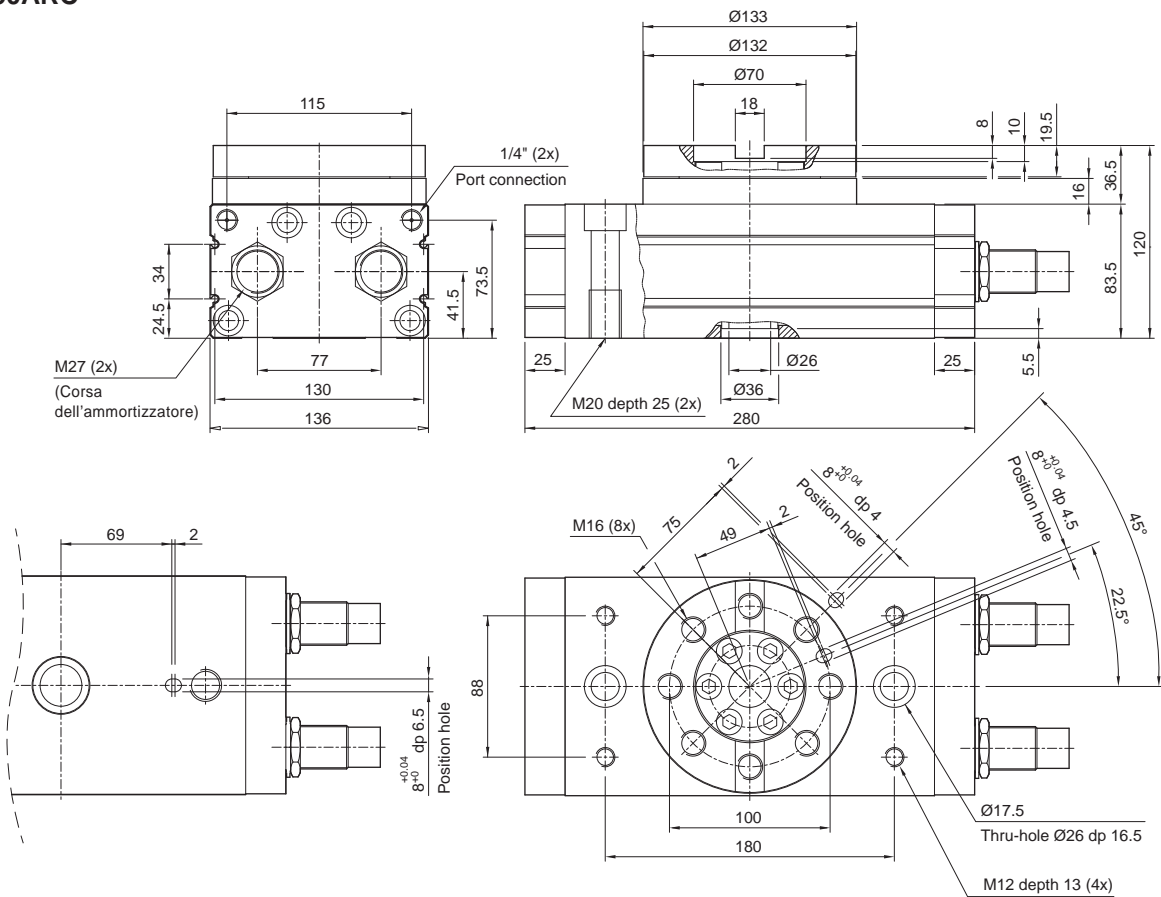



Type: 63ARC

