

Esecuzioni standard		
Version	Code	Item
Bore 15 mm (x2), 90°	073071	15/90ARP
Bore 18 mm (x2), 90°	073072	18/90ARP
Bore 20 mm (x2), 90°	073073	20/90ARP
Bore 25 mm (x2), 90°	073074	25/90ARP
Bore 28 mm (x2), 90°	075588 <i>New</i>	28/90ARP
Bore 32 mm (x2), 90°	075589 <i>New</i>	32/90ARP
Bore 15 mm (x2), 180°	073079	15/180ARP
Bore 18 mm (x2), 180°	073080	18/180ARP
Bore 20 mm (x2), 180°	073081	20/180ARP
Bore 25 mm (x2), 180°	073082	25/180ARP
Bore 28 mm (x2), 180°	075590 <i>New</i>	28/180ARP
Bore 32 mm (x2), 180°	075591 <i>New</i>	32/180ARP

*New*

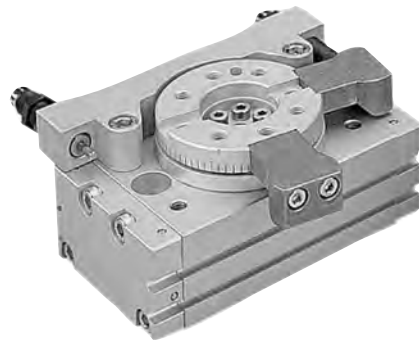

1

Options	Suffix
With hydraulic shock absorbers	D

### How to choose the shock absorber

Rotary actuator	Cushioning capability max (kgf.m)
15ARP	3
18ARP	6
20ARP	6
25ARP	20
28ARP	59
32ARP	59

Series of rotary actuators with piston and external mechanical stoppers.

Rotation angles 90°-180°.

They are standard magnetic provided with grooves on the body allowing the direct mounting of the magnetic reed switches.

The mechanical stoppers are standard; the hydraulic shock absorbers can be supplied on request.

For the magnetic reed switches type ASC see from page 1.110.1

How to order: 20ARCD

20	/	90	ARP	D
Bore	/	Rotation	Item	Option

Technical data							
Type	15	18	20	25	28	32	
Bore	Ø 15	Ø 18	Ø 20	Ø 25	Ø 28	Ø 32	
Fluid	Compressed filtered air with or without lubrication. Lubrication, if started, must be continued.						
Pressure range	1,5 ÷ 7 bar						
Temperature range	0° C ÷ + 50° C						
Rotation angle	90° - 180°						
Adjustment angle	10°						
Rotation moments (Nm)	1,5	2,2	3,2	5,5	7,5	9,8	
Ports	M5			1/8"			
Weight (g)	90°	630	1200	1520	2480	3390	4700
	180°	600	1140	1450	2370	3210	4500

Rotation angles

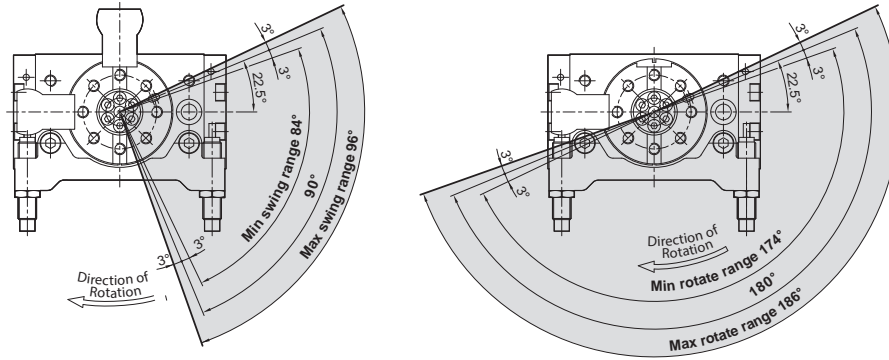

Dimensions

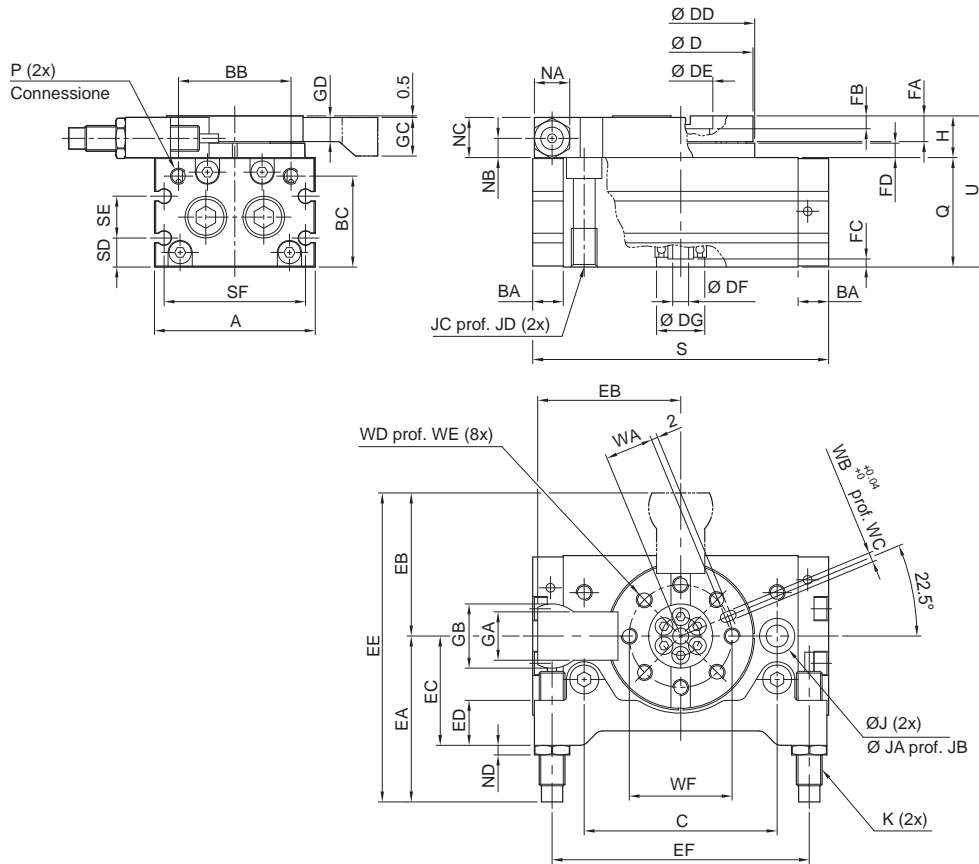

Type	A	BA	BB	BC	C	D	DD	DE	DF	DG	EA	EB	EC	ED	EE	EF	FA	FB	FC	FD	GA	GB	GC	GD	H
15ARP	50	9,5	35	28,2	60	45	46	20	5	15	51,6	44,5	34	14	96,1	80	8	4	2,5	4,5	15	20	12	7,5	13
18ARP	65	12	50,8	28,6	76	60	61	28	9	17	56	57	43	18	113	101	9,7	6,5	2,5	6,6	19	25	9	9,2	17
20ARP	70	12	52	33	84	65	67	32	9	22	59	62	46	18	121	110	10	4,5	3	6,5	20	28	16	9,5	17
25ARP	80	15,5	62	37,5	100	75	77	35	10	26	85	73	55	20	158	131	12	5	2	7,5	25	35	18	11,5	20
28ARP	92	17	70	46,7	110	88	90	46	16	22	86	81	55,5	35	167	141	12,5	5	4	9	28	38	19,5	11,5	22
32ARP	102	14	82	50,3	130	98	100	56	19	24	94	92,5	60	35	186,5	163	14,5	6	4	12	33	42	24,5	13,5	27

Type	J	JA	JB	JC	JD	K	NA	NB	NC	ND	P	Q	S	SD	SE	SF	U	WA	WB	WC	WD	WE	WF
15ARP	6,8	11	6,5	M8x1,25	12	M8x1	11	6	12,5	3	M5x0,8	34	92	9	13	44	47	15	3	3,5	M5x0,8	8	32
18ARP	8,6	14	8,5	M10x1,5	15	M10x1	12,7	7,5	16,5	3	M5x0,8	37	117	10	12	59	54	20,5	4	5	M6x1	10	43
20ARP	8,6	14	8,5	M10x1,5	15	M10x1	12,7	8,5	16,5	3	RC 1/8	40	127	11,5	14	64	57	23	4	4,5	M6x1	10	48
25ARP	10,5	17	10,5	M12x1,75	18	M14x1,5	19	8,5	19,5	5	RC 1/8	46	152	14,5	15	74	66	26,5	5	5,5	M8x1,25	10	55
28ARP	10,5	17	10,5	M12x1,75	18	M14x1,5	19	10	21,5	5	RC 1/8	53	170	14,5	24	78	75	32,5	5	5,5	M8x1,25	12,5	67
32ARP	10,5	17	10,5	M12x1,75	18	M20x1,5	26	11,5	26	7	RC 1/8	59	189	16	27	89	86	37,5	6	6,5	M10x1,5	14,5	77